

EN 12101-8

# MANDÍK<sup>®</sup>

## SINGLE COMPARTMENT SMOKE CONTROL DAMPER

### SEDS



These technical specifications state a row of manufactured sizes and models of Single compartment smoke control damper (further only dampers) SEDS. It is valid for production, designing, ordering, delivery, maintenance and operation.

**I. CONTENT**

<b>II. GENERAL INFORMATION</b>	<b>3</b>
1. Description.....	3
2. Design.....	4
3. Dimensions, weights.....	6
4. Placement and Assembly.....	19
5. Suspension systems.....	20
<b>III. TECHNICAL DATA</b>	<b>21</b>
6. Pressure loss.....	21
7. Coefficient of local pressure loss.....	22
8. Electrical components, wiring diagrams.....	23
<b>IV. MATERIAL, FINISHING</b>	<b>29</b>
9. Material.....	29
<b>V. INSPECTION, TESTING</b>	<b>29</b>
10. Inspection, testing.....	29
<b>VI. TRANSPORTATION AND STORAGE</b>	<b>30</b>
11. Logistic terms.....	30
<b>VII. ASSEMBLY, ATTENDANCE, MAINTENANCE AND REVISIONS</b>	<b>30</b>
12. Assembly.....	30
13. Entry into service and revisions.....	30
14. Spare parts.....	30
<b>VIII. PRODUCT DATA</b>	<b>31</b>
15. Nameplate.....	31
<b>IX. ORDERING INFORMATION</b>	<b>31</b>
16. Ordering key.....	31

## II. GENERAL INFORMATION

### 1. Description

Fig. 1 Damper SEDS



- 1.1. Single compartment smoke control damper are shutters in smoke exhaust duct systems. Dampers are designed to remove heat and combustion products (e.g. smoke) from single fire compartment. The damper blade is operated by an actuating mechanism. The dampers can be installed in various duct sizes with respect to the field of direct applications according with EN 1366-9.
- 1.2. The field of direct applications based on tests results is acceptable according to EN 1363-1, part A.1 and A.2, EN 1366-2, part 13 and EN 1366-10, part 9.  
Declaration of Performance No. PM/SEDS/01/22/1
- 1.3. Dampers are designed for smoke exhaust duct systems with underpressure max. -1000 Pa or overpressure max. 500 Pa.
- 1.4. Dampers are designed for maximum air velocity 15 m/s.
- 1.5. Single compartment smoke control damper are classified as  
**E<sub>600</sub> 90 (v<sub>e-i</sub>↔o) S1000C<sub>300</sub>AAsingle**
- 1.6. In the event of fire the Smoke and Fire ventilation system opens the damper in the affected section which removes combustion products and heat from this section.
- 1.7. Dampers are designed for installation with horizontal blade axis. Flow direction has to be led from actuating side (it is labeled by arrow on the damper casing).
- 1.8. Dampers are designed for macroclimatic areas with mild climate according to EN 60 721-3-3.
- 1.9. Temperature in the place of installation is permitted to range from -30°C to +50°C.
- 1.10. The duck can be ended by SMM (TPM 014/01) or KMM (TPM 002/96) grilles. During grilles installation blade overlaps has to be respected see chapter 3.3.
- 1.11. If is not noticed other way, all dimensions and weight are in millimeters and kilograms.

## 2. Design

### 2.1. Design with actuating mechanism

#### 2.1.1. Belimo actuators are used for dampers, series BEN, BEE, BE for 230V AC resp. 24 V AC / DC, Schischek InMax 50.75-S actuators (universal 24V or 230V supply) are used for large size of dampers.

After connection to the power supply voltage, the actuator moves the damper blade to the "OPEN" position or "CLOSED" (according to the corresponding connection, see wiring diagram). If the power supply is interrupted, the actuator stops at the current position. The signalling of the "OPEN" and "CLOSED" damper blade positions is ensured by two built-in fixed "potential-free" end-limit switches.

### 2.2. Design with the communication and supply device

#### 2.2.1. Design with communication and power supply device BKNE 230-24 and with actuator BEN (BEE, BE)-ST for 24V.

The BKNE 230-24 serves on the one hand as a decentralized network device for powering the actuator and on the other hand transmits the signal of the communication and control device BKSE 24-6.

It simplifies electrical installation and connection of dampers. In the meantime, it facilitates "on-site inspection" and allows central control and inspection of dampers using a simple 2-wire line.

The BKNE 230-24 transmits the "OPEN" / "CLOSED" damper position (switches in the actuator) and fault messages to the BKSE 24-6. It also receives commands from the control device and controls the adjustment of the actuator to the desired position. The last control command will be retained even after a temporary network failure.

The BKNE 230-24 controls the switching position of the actuator, its adjustment time and the data exchange with the BKSE 24-6. In addition, it controls the actuator current (actuator connection) and the power supply.

To simplify the connection, the actuator is equipped with plug connectors that plug directly into the BKNE 230-24.

For more information on actuators and devices, see the Belimo catalogue.

This variant is not available for dampers with Schischek InMax 50.75-S actuator.

### 2.3. Communication and control devices

- 2.3.1.** BKSE 24-6 indicates operating status and fault signals for the smoke control dampers. The auxiliary contacts that are incorporated also allow functions to be signaled or passed on to higherlevel control systems. The signals from the BKNE 230-24 unit are received by the BKSE 24-6 unit and evaluated individually. All BKNE 230-24 units are triggered simultaneously. To BKSE 24-6 can be connected max. 6 BKNE 230-24.

Communication is via the 2-wire conductor. Correct operation of the dampers is indicated by means of two LEDs. The operating status of the SBSE-Control system and any faults are also indicated by this LED and the corresponding fault LED.

The BKSE 24-6 unit can be clipped directly to a 35 mm DIN mounting rail and connected by means of two 9-pole plug-in terminals.

- 2.4.** Dampers from dimension  $A > 500$  and dimension  $B > 400$  are equipped by reinforcement profile for relevant damper side see fig. 2.

Fig. 2

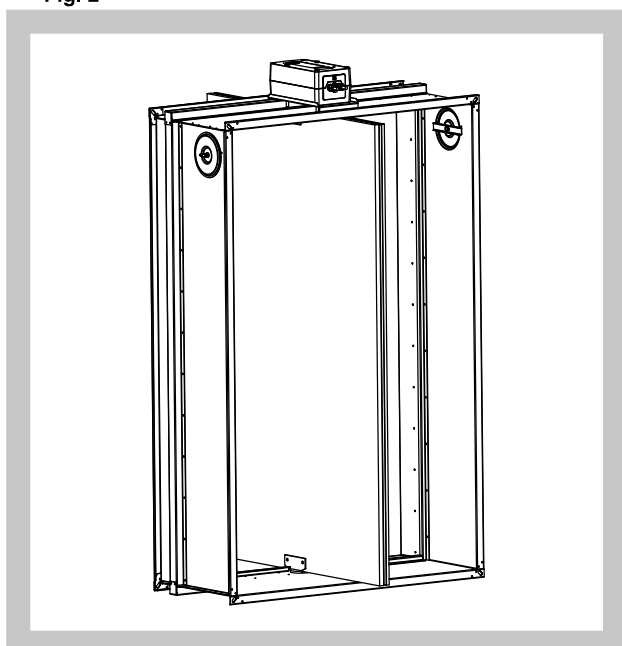

3. Dimensions, weights

3.1. Dimensions

Fig. 3 Single compartment smoke control damper

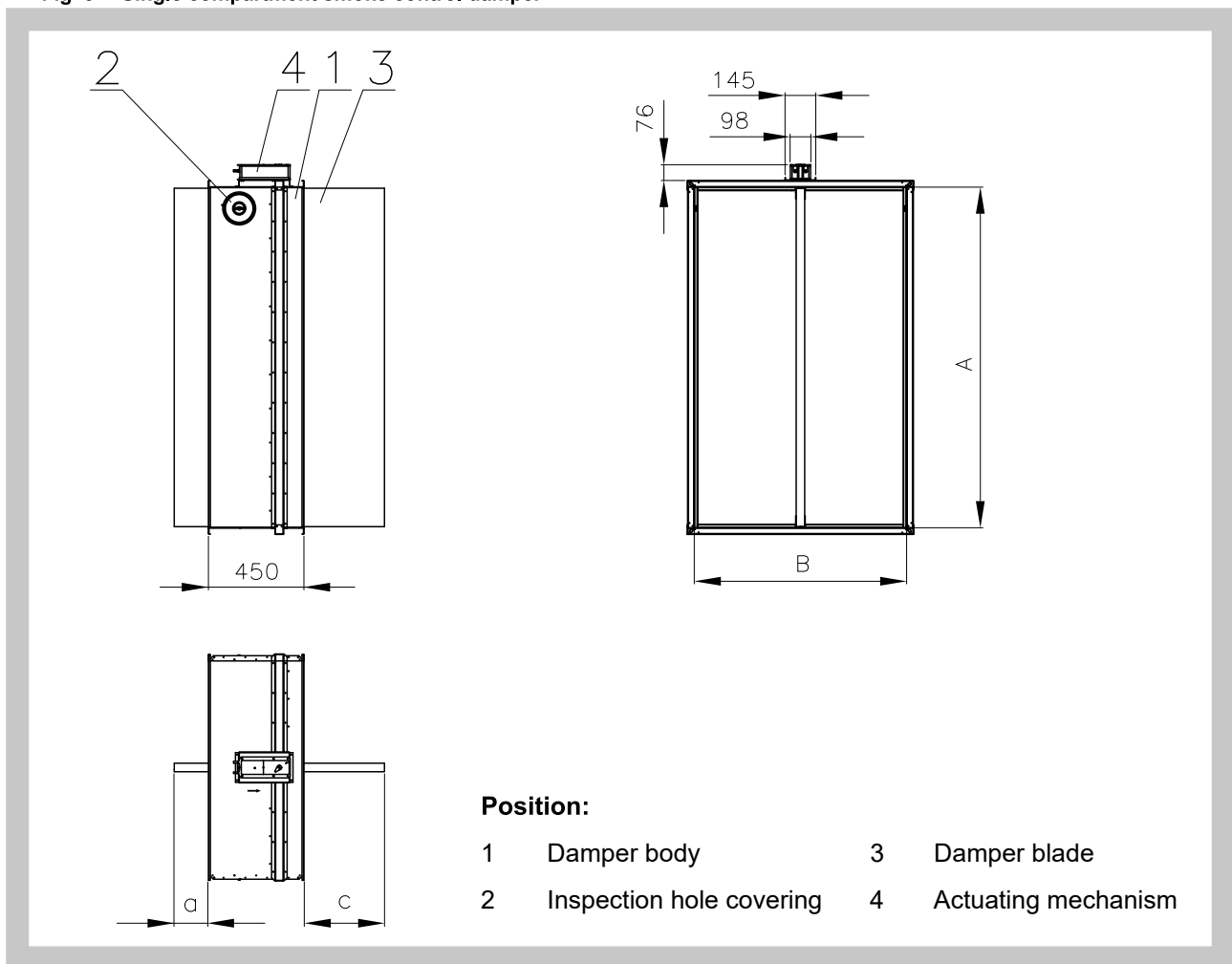

## 3.2. Weights and effective area

Tab. 3.2.1. Weights and effective area

Size AxB	a	c	Weight [kg]	Effective area $S_{ef}$ [m <sup>2</sup> ]	Actuating mechanism type
180 x 180	-	-	12,6	0,016	BELIMO BEN (15 N.m)
x 200	-	-	12,9	0,019	BELIMO BEN (15 N.m)
x 225	-	-	13,4	0,023	BELIMO BEN (15 N.m)
x 250	-	4	13,8	0,026	BELIMO BEN (15 N.m)
x 280	-	19	14,3	0,031	BELIMO BEN (15 N.m)
x 300	-	29	14,6	0,034	BELIMO BEN (15 N.m)
x 315	-	36,5	14,9	0,036	BELIMO BEN (15 N.m)
x 355	-	56,5	15,6	0,042	BELIMO BEN (15 N.m)
x 400	-	79	16,4	0,048	BELIMO BEN (15 N.m)
x 450	-	104	19,1	0,056	BELIMO BEN (15 N.m)
x 500	-	129	20,1	0,063	BELIMO BEN (15 N.m)
x 550	-	154	21,1	0,070	BELIMO BEN (15 N.m)
x 560	-	159	21,3	0,072	BELIMO BEN (15 N.m)
x 600	-	179	22,1	0,078	BELIMO BEN (15 N.m)
x 630	-	194	22,7	0,082	BELIMO BEN (15 N.m)
x 650	-	204	23,1	0,085	BELIMO BEN (15 N.m)
x 700	11	229	24,1	0,093	BELIMO BEN (15 N.m)
x 710	16	234	24,3	0,094	BELIMO BEN (15 N.m)
x 750	36	254	25,1	0,100	BELIMO BEN (15 N.m)
x 800	61	279	26,1	0,107	BELIMO BEN (15 N.m)
x 900	111	329	28,2	0,122	BELIMO BEN (15 N.m)
x 1000	161	379	30,2	0,137	BELIMO BEN (15 N.m)
200 x 180	-	-	12,9	0,018	BELIMO BEN (15 N.m)
x 200	-	-	13,3	0,021	BELIMO BEN (15 N.m)
x 225	-	-	13,7	0,026	BELIMO BEN (15 N.m)
x 250	-	4	14,2	0,030	BELIMO BEN (15 N.m)
x 280	-	19	14,7	0,035	BELIMO BEN (15 N.m)
x 300	-	29	15,1	0,038	BELIMO BEN (15 N.m)
x 315	-	36,5	15,3	0,041	BELIMO BEN (15 N.m)
x 355	-	56,5	16,1	0,047	BELIMO BEN (15 N.m)
x 400	-	79	16,9	0,055	BELIMO BEN (15 N.m)
x 450	-	104	19,7	0,063	BELIMO BEN (15 N.m)
x 500	-	129	20,7	0,072	BELIMO BEN (15 N.m)
x 550	-	154	21,8	0,080	BELIMO BEN (15 N.m)
x 560	-	159	22	0,082	BELIMO BEN (15 N.m)
x 600	-	179	22,8	0,088	BELIMO BEN (15 N.m)
x 630	-	194	23,4	0,093	BELIMO BEN (15 N.m)
x 650	-	204	23,8	0,097	BELIMO BEN (15 N.m)
x 700	11	229	24,9	0,105	BELIMO BEN (15 N.m)
x 710	16	234	25,1	0,107	BELIMO BEN (15 N.m)
x 750	36	254	25,9	0,114	BELIMO BEN (15 N.m)
x 800	61	279	27	0,122	BELIMO BEN (15 N.m)
x 900	111	329	29,1	0,139	BELIMO BEN (15 N.m)
x 1000	161	379	31,1	0,155	BELIMO BEN (15 N.m)
225 x 180	-	-	13,4	0,021	BELIMO BEN (15 N.m)
x 200	-	-	13,7	0,025	BELIMO BEN (15 N.m)
x 225	-	-	14,2	0,029	BELIMO BEN (15 N.m)
x 250	-	4	14,7	0,034	BELIMO BEN (15 N.m)
x 280	-	19	15,2	0,040	BELIMO BEN (15 N.m)

Size AxB	a	c	Weight [kg]	Effective area S <sub>ef</sub> [m <sup>2</sup> ]	Actuating mechanism type
<b>225 x 300</b>	-	29	15,6	0,044	BELIMO BEN (15 N.m)
<b>x 315</b>	-	36,5	15,9	0,047	BELIMO BEN (15 N.m)
<b>x 355</b>	-	56,5	16,6	0,054	BELIMO BEN (15 N.m)
<b>x 400</b>	-	79	17,5	0,063	BELIMO BEN (15 N.m)
<b>x 450</b>	-	104	20,4	0,073	BELIMO BEN (15 N.m)
<b>x 500</b>	-	129	21,5	0,082	BELIMO BEN (15 N.m)
<b>x 550</b>	-	154	22,6	0,092	BELIMO BEN (15 N.m)
<b>x 560</b>	-	159	22,8	0,094	BELIMO BEN (15 N.m)
<b>x 600</b>	-	179	23,7	0,102	BELIMO BEN (15 N.m)
<b>x 630</b>	-	194	24,3	0,107	BELIMO BEN (15 N.m)
<b>x 650</b>	-	204	24,7	0,111	BELIMO BEN (15 N.m)
<b>x 700</b>	11	229	25,8	0,121	BELIMO BEN (15 N.m)
<b>x 710</b>	16	234	26,1	0,123	BELIMO BEN (15 N.m)
<b>x 750</b>	36	254	26,9	0,131	BELIMO BEN (15 N.m)
<b>x 800</b>	61	279	28	0,140	BELIMO BEN (15 N.m)
<b>x 900</b>	111	329	30,2	0,159	BELIMO BEN (15 N.m)
<b>x 1000</b>	161	379	32,4	0,179	BELIMO BEN (15 N.m)
<b>250 x 180</b>	-	-	13,8	0,023	BELIMO BEN (15 N.m)
<b>x 200</b>	-	-	14,2	0,028	BELIMO BEN (15 N.m)
<b>x 225</b>	-	-	14,7	0,033	BELIMO BEN (15 N.m)
<b>x 250</b>	-	4	15,2	0,039	BELIMO BEN (15 N.m)
<b>x 280</b>	-	19	15,7	0,045	BELIMO BEN (15 N.m)
<b>x 300</b>	-	29	16,1	0,050	BELIMO BEN (15 N.m)
<b>x 315</b>	-	37	16,4	0,053	BELIMO BEN (15 N.m)
<b>x 355</b>	-	57	17,2	0,061	BELIMO BEN (15 N.m)
<b>x 400</b>	-	79	18,1	0,071	BELIMO BEN (15 N.m)
<b>x 450</b>	-	104	21,1	0,082	BELIMO BEN (15 N.m)
<b>x 500</b>	-	129	22,3	0,093	BELIMO BEN (15 N.m)
<b>x 550</b>	-	154	23,4	0,104	BELIMO BEN (15 N.m)
<b>x 560</b>	-	159	23,6	0,106	BELIMO BEN (15 N.m)
<b>x 600</b>	-	179	24,5	0,115	BELIMO BEN (15 N.m)
<b>x 630</b>	-	194	25,2	0,121	BELIMO BEN (15 N.m)
<b>x 650</b>	-	204	25,7	0,126	BELIMO BEN (15 N.m)
<b>x 700</b>	11	229	26,8	0,137	BELIMO BEN (15 N.m)
<b>x 710</b>	16	234	27	0,139	BELIMO BEN (15 N.m)
<b>x 750</b>	36	254	27,9	0,147	BELIMO BEN (15 N.m)
<b>x 800</b>	61	279	29	0,158	BELIMO BEN (15 N.m)
<b>x 900</b>	111	329	31,3	0,180	BELIMO BEN (15 N.m)
<b>x 1000</b>	161	379	33,6	0,202	BELIMO BEN (15 N.m)
<b>280 x 180</b>	-	-	14,3	0,027	BELIMO BEN (15 N.m)
<b>x 200</b>	-	-	14,7	0,032	BELIMO BEN (15 N.m)
<b>x 225</b>	-	-	15,2	0,038	BELIMO BEN (15 N.m)
<b>x 250</b>	-	4	15,7	0,044	BELIMO BEN (15 N.m)
<b>x 280</b>	-	19	16,4	0,051	BELIMO BEN (15 N.m)
<b>x 300</b>	-	29	16,8	0,056	BELIMO BEN (15 N.m)
<b>x 315</b>	-	36,5	17,1	0,060	BELIMO BEN (15 N.m)
<b>x 355</b>	-	56,5	17,9	0,070	BELIMO BEN (15 N.m)
<b>x 400</b>	-	79	18,8	0,081	BELIMO BEN (15 N.m)
<b>x 450</b>	-	104	22	0,093	BELIMO BEN (15 N.m)
<b>x 500</b>	-	129	23,2	0,106	BELIMO BEN (15 N.m)
<b>x 550</b>	-	154	24,4	0,118	BELIMO BEN (15 N.m)
<b>x 560</b>	-	159	24,6	0,121	BELIMO BEN (15 N.m)
<b>x 600</b>	-	179	25,6	0,131	BELIMO BEN (15 N.m)

Size AxB	a	c	Weight [kg]	Effective area $S_{ef}$ [m <sup>2</sup> ]	Actuating mechanism type
<b>280 x 630</b>	-	194	26,3	0,138	BELIMO BEN (15 N.m)
<b>x 650</b>	-	204	26,7	0,143	BELIMO BEN (15 N.m)
<b>x 700</b>	11	229	27,9	0,155	BELIMO BEN (15 N.m)
<b>x 710</b>	16	234	28,2	0,158	BELIMO BEN (15 N.m)
<b>x 750</b>	36	254	29,1	0,168	BELIMO BEN (15 N.m)
<b>x 800</b>	61	279	30,3	0,180	BELIMO BEN (15 N.m)
<b>x 900</b>	111	329	32,6	0,205	BELIMO BEN (15 N.m)
<b>x 1000</b>	161	379	35	0,230	BELIMO BEN (15 N.m)
<b>300 x 180</b>	-	-	14,6	0,029	BELIMO BEN (15 N.m)
<b>x 200</b>	-	-	15,1	0,034	BELIMO BEN (15 N.m)
<b>x 225</b>	-	-	15,6	0,041	BELIMO BEN (15 N.m)
<b>x 250</b>	-	4	16,1	0,048	BELIMO BEN (15 N.m)
<b>x 280</b>	-	19	16,8	0,056	BELIMO BEN (15 N.m)
<b>x 300</b>	-	29	17,2	0,061	BELIMO BEN (15 N.m)
<b>x 315</b>	-	36,5	17,5	0,065	BELIMO BEN (15 N.m)
<b>x 355</b>	-	56,5	18,4	0,076	BELIMO BEN (15 N.m)
<b>x 400</b>	-	79	19,3	0,088	BELIMO BEN (15 N.m)
<b>x 450</b>	-	104	22,6	0,101	BELIMO BEN (15 N.m)
<b>x 500</b>	-	129	23,8	0,114	BELIMO BEN (15 N.m)
<b>x 550</b>	-	154	25	0,128	BELIMO BEN (15 N.m)
<b>x 560</b>	-	159	25,3	0,130	BELIMO BEN (15 N.m)
<b>x 600</b>	-	179	26,3	0,141	BELIMO BEN (15 N.m)
<b>x 630</b>	-	194	27	0,149	BELIMO BEN (15 N.m)
<b>x 650</b>	-	204	27,5	0,155	BELIMO BEN (15 N.m)
<b>x 700</b>	11	229	28,7	0,168	BELIMO BEN (15 N.m)
<b>x 710</b>	16	234	28,9	0,171	BELIMO BEN (15 N.m)
<b>x 750</b>	36	254	29,9	0,181	BELIMO BEN (15 N.m)
<b>x 800</b>	61	279	31,1	0,195	BELIMO BEN (15 N.m)
<b>x 900</b>	111	329	33,5	0,221	BELIMO BEN (15 N.m)
<b>x 1000</b>	161	379	36	0,248	BELIMO BEN (15 N.m)
<b>315 x 180</b>	-	-	14,9	0,030	BELIMO BEN (15 N.m)
<b>x 200</b>	-	-	15,3	0,036	BELIMO BEN (15 N.m)
<b>x 225</b>	-	-	15,9	0,043	BELIMO BEN (15 N.m)
<b>x 250</b>	-	4	16,4	0,050	BELIMO BEN (15 N.m)
<b>x 280</b>	-	19	17,1	0,059	BELIMO BEN (15 N.m)
<b>x 300</b>	-	29	17,5	0,064	BELIMO BEN (15 N.m)
<b>x 315</b>	-	36,5	17,9	0,069	BELIMO BEN (15 N.m)
<b>x 355</b>	-	56,5	18,7	0,080	BELIMO BEN (15 N.m)
<b>x 400</b>	-	79	19,7	0,093	BELIMO BEN (15 N.m)
<b>x 450</b>	-	104	23	0,107	BELIMO BEN (15 N.m)
<b>x 500</b>	-	129	24,3	0,121	BELIMO BEN (15 N.m)
<b>x 550</b>	-	154	25,5	0,135	BELIMO BEN (15 N.m)
<b>x 560</b>	-	159	25,8	0,138	BELIMO BEN (15 N.m)
<b>x 600</b>	-	179	26,8	0,149	BELIMO BEN (15 N.m)
<b>x 630</b>	-	194	27,5	0,158	BELIMO BEN (15 N.m)
<b>x 650</b>	-	204	28	0,163	BELIMO BEN (15 N.m)
<b>x 700</b>	11	229	29,3	0,177	BELIMO BEN (15 N.m)
<b>x 710</b>	16	234	29,5	0,180	BELIMO BEN (15 N.m)
<b>x 750</b>	36	254	30,5	0,191	BELIMO BEN (15 N.m)
<b>x 800</b>	61	279	31,7	0,206	BELIMO BEN (15 N.m)
<b>x 900</b>	111	329	34,2	0,234	BELIMO BEN (15 N.m)
<b>x 1000</b>	161	379	36,7	0,262	BELIMO BEN (15 N.m)
<b>355 x 180</b>	-	-	15,6	0,035	BELIMO BEN (15 N.m)

Size AxB	a	c	Weight [kg]	Effective area $S_{ef}$ [m <sup>2</sup> ]	Actuating mechanism type
<b>355 x 200</b>	-	-	16,1	0,041	BELIMO BEN (15 N.m)
<b>x 225</b>	-	-	16,6	0,049	BELIMO BEN (15 N.m)
<b>x 250</b>	-	4	17,2	0,057	BELIMO BEN (15 N.m)
<b>x 280</b>	-	19	17,9	0,067	BELIMO BEN (15 N.m)
<b>x 300</b>	-	29	18,4	0,073	BELIMO BEN (15 N.m)
<b>x 315</b>	-	36,5	18,7	0,078	BELIMO BEN (15 N.m)
<b>x 355</b>	-	56,5	19,7	0,091	BELIMO BEN (15 N.m)
<b>x 400</b>	-	79	20,7	0,106	BELIMO BEN (15 N.m)
<b>x 450</b>	-	104	24,2	0,122	BELIMO BEN (15 N.m)
<b>x 500</b>	-	129	25,5	0,138	BELIMO BEN (15 N.m)
<b>x 550</b>	-	154	26,8	0,154	BELIMO BEN (15 N.m)
<b>x 560</b>	-	159	27,1	0,157	BELIMO BEN (15 N.m)
<b>x 600</b>	-	179	28,2	0,170	BELIMO BEN (15 N.m)
<b>x 630</b>	-	194	28,9	0,180	BELIMO BEN (15 N.m)
<b>x 650</b>	-	204	29,5	0,186	BELIMO BEN (15 N.m)
<b>x 700</b>	11	229	30,8	0,202	BELIMO BEN (15 N.m)
<b>x 710</b>	16	234	31	0,206	BELIMO BEN (15 N.m)
<b>x 750</b>	36	254	32,1	0,219	BELIMO BEN (15 N.m)
<b>x 800</b>	61	279	33,4	0,235	BELIMO BEN (15 N.m)
<b>x 900</b>	111	329	36	0,267	BELIMO BEN (15 N.m)
<b>x 1000</b>	161	379	38,6	0,299	BELIMO BEN (15 N.m)
<b>400 x 180</b>	-	-	16,4	0,040	BELIMO BEN (15 N.m)
<b>x 200</b>	-	-	16,9	0,047	BELIMO BEN (15 N.m)
<b>x 225</b>	-	-	17,5	0,056	BELIMO BEN (15 N.m)
<b>x 250</b>	-	4	18,1	0,065	BELIMO BEN (15 N.m)
<b>x 280</b>	-	19	18,8	0,076	BELIMO BEN (15 N.m)
<b>x 300</b>	-	29	19,3	0,084	BELIMO BEN (15 N.m)
<b>x 315</b>	-	36,5	19,7	0,089	BELIMO BEN (15 N.m)
<b>x 355</b>	-	56,5	20,7	0,104	BELIMO BEN (15 N.m)
<b>x 400</b>	-	79	21,8	0,120	BELIMO BEN (15 N.m)
<b>x 450</b>	-	104	25,5	0,139	BELIMO BEN (15 N.m)
<b>x 500</b>	-	129	26,9	0,157	BELIMO BEN (15 N.m)
<b>x 550</b>	-	154	28,3	0,176	BELIMO BEN (15 N.m)
<b>x 560</b>	-	159	28,6	0,179	BELIMO BEN (15 N.m)
<b>x 600</b>	-	179	29,7	0,194	BELIMO BEN (15 N.m)
<b>x 630</b>	-	194	30,5	0,205	BELIMO BEN (15 N.m)
<b>x 650</b>	-	204	31,1	0,212	BELIMO BEN (15 N.m)
<b>x 700</b>	11	229	32,5	0,231	BELIMO BEN (15 N.m)
<b>x 710</b>	16	234	32,8	0,234	BELIMO BEN (15 N.m)
<b>x 750</b>	36	254	33,9	0,249	BELIMO BEN (15 N.m)
<b>x 800</b>	61	279	35,3	0,267	BELIMO BEN (15 N.m)
<b>x 900</b>	111	329	38	0,304	BELIMO BEN (15 N.m)
<b>x 1000</b>	161	379	40,8	0,341	BELIMO BEN (15 N.m)
<b>450 x 180</b>	-	-	17,2	0,045	BELIMO BEN (15 N.m)
<b>x 200</b>	-	-	17,7	0,053	BELIMO BEN (15 N.m)
<b>x 225</b>	-	-	18,4	0,064	BELIMO BEN (15 N.m)
<b>x 250</b>	-	4	19,1	0,074	BELIMO BEN (15 N.m)
<b>x 280</b>	-	19	19,9	0,087	BELIMO BEN (15 N.m)
<b>x 300</b>	-	29	20,4	0,095	BELIMO BEN (15 N.m)
<b>x 315</b>	-	36,5	20,8	0,101	BELIMO BEN (15 N.m)
<b>x 355</b>	-	56,5	21,9	0,118	BELIMO BEN (15 N.m)
<b>x 400</b>	-	79	23	0,137	BELIMO BEN (15 N.m)
<b>x 450</b>	-	104	27	0,158	BELIMO BEN (15 N.m)

Size AxB	a	c	Weight [kg]	Effective area $S_{ef}$ [m <sup>2</sup> ]	Actuating mechanism type
<b>450 x 500</b>	-	129	28,5	0,179	BELIMO BEN (15 N.m)
<b>x 550</b>	-	154	30	0,199	BELIMO BEN (15 N.m)
<b>x 560</b>	-	159	30,2	0,204	BELIMO BEN (15 N.m)
<b>x 600</b>	-	179	31,4	0,220	BELIMO BEN (15 N.m)
<b>x 630</b>	-	194	32,3	0,233	BELIMO BEN (15 N.m)
<b>x 650</b>	-	204	32,9	0,241	BELIMO BEN (15 N.m)
<b>x 700</b>	11	229	34,4	0,262	BELIMO BEN (15 N.m)
<b>x 710</b>	16	234	34,7	0,266	BELIMO BEN (15 N.m)
<b>x 750</b>	36	254	35,9	0,283	BELIMO BEN (15 N.m)
<b>x 800</b>	61	279	37,3	0,304	BELIMO BEN (15 N.m)
<b>x 900</b>	111	329	40,3	0,346	BELIMO BEN (15 N.m)
<b>x 1000</b>	161	379	44,3	0,387	BELIMO BEE (25 N.m)
<b>500 x 180</b>	-	-	20	0,050	BELIMO BEN (15 N.m)
<b>x 200</b>	-	-	20,7	0,060	BELIMO BEN (15 N.m)
<b>x 225</b>	-	-	21,4	0,071	BELIMO BEN (15 N.m)
<b>x 250</b>	-	4	22,2	0,083	BELIMO BEN (15 N.m)
<b>x 280</b>	-	19	23,2	0,097	BELIMO BEN (15 N.m)
<b>x 300</b>	-	29	23,8	0,106	BELIMO BEN (15 N.m)
<b>x 315</b>	-	36,5	24,2	0,113	BELIMO BEN (15 N.m)
<b>x 355</b>	-	56,5	25,5	0,132	BELIMO BEN (15 N.m)
<b>x 400</b>	-	79	26,9	0,153	BELIMO BEN (15 N.m)
<b>x 450</b>	-	104	28,5	0,177	BELIMO BEN (15 N.m)
<b>x 500</b>	-	129	30	0,200	BELIMO BEN (15 N.m)
<b>x 550</b>	-	154	31,6	0,223	BELIMO BEN (15 N.m)
<b>x 560</b>	-	159	31,9	0,228	BELIMO BEN (15 N.m)
<b>x 600</b>	-	179	33,2	0,247	BELIMO BEN (15 N.m)
<b>x 630</b>	-	194	34,1	0,261	BELIMO BEN (15 N.m)
<b>x 650</b>	-	204	34,7	0,270	BELIMO BEN (15 N.m)
<b>x 700</b>	11	229	36,3	0,293	BELIMO BEN (15 N.m)
<b>x 710</b>	16	234	36,6	0,298	BELIMO BEN (15 N.m)
<b>x 750</b>	36	254	37,8	0,317	BELIMO BEN (15 N.m)
<b>x 800</b>	61	279	39,4	0,340	BELIMO BEN (15 N.m)
<b>x 900</b>	111	329	42,5	0,387	BELIMO BEN (15 N.m)
<b>x 1000</b>	161	379	46,7	0,434	BELIMO BEE (25 N.m)
<b>550 x 180</b>	-	-	21	0,056	BELIMO BEN (15 N.m)
<b>x 200</b>	-	-	21,7	0,066	BELIMO BEN (15 N.m)
<b>x 225</b>	-	-	22,5	0,079	BELIMO BEN (15 N.m)
<b>x 250</b>	-	4	23,3	0,092	BELIMO BEN (15 N.m)
<b>x 280</b>	-	19	24,3	0,107	BELIMO BEN (15 N.m)
<b>x 300</b>	-	29	25	0,118	BELIMO BEN (15 N.m)
<b>x 315</b>	-	36,5	25,5	0,126	BELIMO BEN (15 N.m)
<b>x 355</b>	-	56,5	26,8	0,146	BELIMO BEN (15 N.m)
<b>x 400</b>	-	79	28,3	0,170	BELIMO BEN (15 N.m)
<b>x 450</b>	-	104	29,9	0,195	BELIMO BEN (15 N.m)
<b>x 500</b>	-	129	31,6	0,221	BELIMO BEN (15 N.m)
<b>x 550</b>	-	154	33,2	0,247	BELIMO BEN (15 N.m)
<b>x 560</b>	-	159	33,6	0,252	BELIMO BEN (15 N.m)
<b>x 600</b>	-	179	34,9	0,273	BELIMO BEN (15 N.m)
<b>x 630</b>	-	194	35,9	0,289	BELIMO BEN (15 N.m)
<b>x 650</b>	-	204	36,5	0,299	BELIMO BEN (15 N.m)
<b>x 700</b>	11	229	38,2	0,325	BELIMO BEN (15 N.m)
<b>x 710</b>	16	234	38,5	0,330	BELIMO BEN (15 N.m)
<b>x 750</b>	36	254	39,8	0,351	BELIMO BEN (15 N.m)

Size AxB	a	c	Weight [kg]	Effective area $S_{ef}$ [m <sup>2</sup> ]	Actuating mechanism type
<b>550 x 800</b>	61	279	41,5	0,377	BELIMO BEN (15 N.m)
<b>x 900</b>	111	329	45,8	0,428	BELIMO BEE (25 N.m)
<b>x 1000</b>	161	379	49,1	0,480	BELIMO BEE (25 N.m)
<b>560 x 180</b>	-	-	21,2	0,057	BELIMO BEN (15 N.m)
<b>x 200</b>	-	-	21,9	0,067	BELIMO BEN (15 N.m)
<b>x 225</b>	-	-	22,7	0,081	BELIMO BEN (15 N.m)
<b>x 250</b>	-	4	23,6	0,094	BELIMO BEN (15 N.m)
<b>x 280</b>	-	19	24,6	0,110	BELIMO BEN (15 N.m)
<b>x 300</b>	-	29	25,2	0,120	BELIMO BEN (15 N.m)
<b>x 315</b>	-	36,5	25,7	0,128	BELIMO BEN (15 N.m)
<b>x 355</b>	-	56,5	27,1	0,149	BELIMO BEN (15 N.m)
<b>x 400</b>	-	79	28,6	0,173	BELIMO BEN (15 N.m)
<b>x 450</b>	-	104	30,2	0,199	BELIMO BEN (15 N.m)
<b>x 500</b>	-	129	31,9	0,226	BELIMO BEN (15 N.m)
<b>x 550</b>	-	154	33,6	0,252	BELIMO BEN (15 N.m)
<b>x 560</b>	-	159	33,9	0,257	BELIMO BEN (15 N.m)
<b>x 600</b>	-	179	35,2	0,278	BELIMO BEN (15 N.m)
<b>x 630</b>	-	194	36,2	0,294	BELIMO BEN (15 N.m)
<b>x 650</b>	-	204	36,9	0,305	BELIMO BEN (15 N.m)
<b>x 700</b>	11	229	38,6	0,331	BELIMO BEN (15 N.m)
<b>x 710</b>	16	234	38,9	0,336	BELIMO BEN (15 N.m)
<b>x 750</b>	36	254	40,2	0,358	BELIMO BEN (15 N.m)
<b>x 800</b>	61	279	41,9	0,384	BELIMO BEN (15 N.m)
<b>x 900</b>	111	329	46,2	0,437	BELIMO BEE (25 N.m)
<b>x 1000</b>	161	379	49,6	0,489	BELIMO BEE (25 N.m)
<b>600 x 180</b>	-	-	22	0,061	BELIMO BEN (15 N.m)
<b>x 200</b>	-	-	22,7	0,072	BELIMO BEN (15 N.m)
<b>x 225</b>	-	-	23,6	0,087	BELIMO BEN (15 N.m)
<b>x 250</b>	-	4	24,5	0,101	BELIMO BEN (15 N.m)
<b>x 280</b>	-	19	25,5	0,118	BELIMO BEN (15 N.m)
<b>x 300</b>	-	29	26,2	0,129	BELIMO BEN (15 N.m)
<b>x 315</b>	-	36,5	26,7	0,138	BELIMO BEN (15 N.m)
<b>x 355</b>	-	56,5	28,1	0,160	BELIMO BEN (15 N.m)
<b>x 400</b>	-	79	29,7	0,186	BELIMO BEN (15 N.m)
<b>x 450</b>	-	104	31,4	0,214	BELIMO BEN (15 N.m)
<b>x 500</b>	-	129	33,1	0,243	BELIMO BEN (15 N.m)
<b>x 550</b>	-	154	34,9	0,271	BELIMO BEN (15 N.m)
<b>x 560</b>	-	159	35,2	0,277	BELIMO BEN (15 N.m)
<b>x 600</b>	-	179	36,6	0,299	BELIMO BEN (15 N.m)
<b>x 630</b>	-	194	37,6	0,316	BELIMO BEN (15 N.m)
<b>x 650</b>	-	204	38,3	0,328	BELIMO BEN (15 N.m)
<b>x 700</b>	11	229	40,1	0,356	BELIMO BEN (15 N.m)
<b>x 710</b>	16	234	40,4	0,362	BELIMO BEN (15 N.m)
<b>x 750</b>	36	254	41,8	0,385	BELIMO BEN (15 N.m)
<b>x 800</b>	61	279	43,6	0,413	BELIMO BEN (15 N.m)
<b>x 900</b>	111	329	48	0,470	BELIMO BEE (25 N.m)
<b>x 1000</b>	161	379	51,5	0,527	BELIMO BEE (25 N.m)
<b>630 x 180</b>	-	-	22,6	0,064	BELIMO BEN (15 N.m)
<b>x 200</b>	-	-	23,3	0,076	BELIMO BEN (15 N.m)
<b>x 225</b>	-	-	24,2	0,091	BELIMO BEN (15 N.m)
<b>x 250</b>	-	4	25,1	0,106	BELIMO BEN (15 N.m)
<b>x 280</b>	-	19	26,2	0,124	BELIMO BEN (15 N.m)
<b>x 300</b>	-	29	26,9	0,136	BELIMO BEN (15 N.m)

Size AxB	a	c	Weight [kg]	Effective area $S_{ef}$ [m <sup>2</sup> ]	Actuating mechanism type
<b>630 x 315</b>	-	36,5	27,5	0,145	BELIMO BEN (15 N.m)
<b>x 355</b>	-	56,5	28,9	0,169	BELIMO BEN (15 N.m)
<b>x 400</b>	-	79	30,5	0,196	BELIMO BEN (15 N.m)
<b>x 450</b>	-	104	32,3	0,226	BELIMO BEN (15 N.m)
<b>x 500</b>	-	129	34,1	0,256	BELIMO BEN (15 N.m)
<b>x 550</b>	-	154	35,9	0,285	BELIMO BEN (15 N.m)
<b>x 560</b>	-	159	36,2	0,291	BELIMO BEN (15 N.m)
<b>x 600</b>	-	179	37,6	0,315	BELIMO BEN (15 N.m)
<b>x 630</b>	-	194	38,7	0,333	BELIMO BEN (15 N.m)
<b>x 650</b>	-	204	39,4	0,345	BELIMO BEN (15 N.m)
<b>x 700</b>	11	229	41,2	0,375	BELIMO BEN (15 N.m)
<b>x 710</b>	16	234	41,6	0,381	BELIMO BEN (15 N.m)
<b>x 750</b>	36	254	43	0,405	BELIMO BEN (15 N.m)
<b>x 800</b>	61	279	44,8	0,435	BELIMO BEN (15 N.m)
<b>x 900</b>	111	329	49,4	0,495	BELIMO BEE (25 N.m)
<b>x 1000</b>	161	379	53	0,554	BELIMO BEE (25 N.m)
<b>650 x 180</b>	-	-	23	0,066	BELIMO BEN (15 N.m)
<b>x 200</b>	-	-	23,8	0,079	BELIMO BEN (15 N.m)
<b>x 225</b>	-	-	24,7	0,094	BELIMO BEN (15 N.m)
<b>x 250</b>	-	4	25,6	0,110	BELIMO BEN (15 N.m)
<b>x 280</b>	-	19	26,7	0,128	BELIMO BEN (15 N.m)
<b>x 300</b>	-	29	27,4	0,141	BELIMO BEN (15 N.m)
<b>x 315</b>	-	36,5	27,9	0,150	BELIMO BEN (15 N.m)
<b>x 355</b>	-	56,5	29,4	0,175	BELIMO BEN (15 N.m)
<b>x 400</b>	-	79	31	0,202	BELIMO BEN (15 N.m)
<b>x 450</b>	-	104	32,9	0,233	BELIMO BEN (15 N.m)
<b>x 500</b>	-	129	34,7	0,264	BELIMO BEN (15 N.m)
<b>x 550</b>	-	154	36,5	0,295	BELIMO BEN (15 N.m)
<b>x 560</b>	-	159	36,9	0,301	BELIMO BEN (15 N.m)
<b>x 600</b>	-	179	38,3	0,326	BELIMO BEN (15 N.m)
<b>x 630</b>	-	194	39,4	0,344	BELIMO BEN (15 N.m)
<b>x 650</b>	-	204	40,2	0,357	BELIMO BEN (15 N.m)
<b>x 700</b>	11	229	42	0,388	BELIMO BEN (15 N.m)
<b>x 710</b>	16	234	42,3	0,394	BELIMO BEN (15 N.m)
<b>x 750</b>	36	254	43,8	0,418	BELIMO BEN (15 N.m)
<b>x 800</b>	61	279	46,6	0,449	BELIMO BEN (15 N.m)
<b>x 900</b>	111	329	50,3	0,511	BELIMO BEE (25 N.m)
<b>x 1000</b>	161	379	53,9	0,573	BELIMO BE (40 N.m)
<b>700 x 180</b>	-	-	24	0,072	BELIMO BEN (15 N.m)
<b>x 200</b>	-	-	24,8	0,085	BELIMO BEN (15 N.m)
<b>x 225</b>	-	-	25,7	0,102	BELIMO BEN (15 N.m)
<b>x 250</b>	-	4	26,7	0,119	BELIMO BEN (15 N.m)
<b>x 280</b>	-	19	27,8	0,139	BELIMO BEN (15 N.m)
<b>x 300</b>	-	29	28,6	0,152	BELIMO BEN (15 N.m)
<b>x 315</b>	-	36,5	29,2	0,162	BELIMO BEN (15 N.m)
<b>x 355</b>	-	56,5	30,7	0,189	BELIMO BEN (15 N.m)
<b>x 400</b>	-	79	32,4	0,219	BELIMO BEN (15 N.m)
<b>x 450</b>	-	104	34,3	0,252	BELIMO BEN (15 N.m)
<b>x 500</b>	-	129	36,2	0,285	BELIMO BEN (15 N.m)
<b>x 550</b>	-	154	38,1	0,319	BELIMO BEN (15 N.m)
<b>x 560</b>	-	159	38,5	0,326	BELIMO BEN (15 N.m)
<b>x 600</b>	-	179	40,1	0,352	BELIMO BEN (15 N.m)
<b>x 630</b>	-	194	41,2	0,372	BELIMO BEN (15 N.m)

Size AxB	a	c	Weight [kg]	Effective area S <sub>ef</sub> [m <sup>2</sup> ]	Actuating mechanism type
<b>700 x 650</b>	-	204	42	0,386	BELIMO BEN (15 N.m)
<b>x 700</b>	11	229	43,9	0,419	BELIMO BEN (15 N.m)
<b>x 710</b>	16	234	44,3	0,426	BELIMO BEN (15 N.m)
<b>x 750</b>	36	254	45,8	0,452	BELIMO BEN (15 N.m)
<b>x 800</b>	61	279	48,7	0,486	BELIMO BEE (25 N.m)
<b>x 900</b>	111	329	52,5	0,553	BELIMO BEE (25 N.m)
<b>x 1000</b>	161	379	56,4	0,619	BELIMO BE (40 N.m)
<b>710 x 180</b>	-	-	24,2	0,073	BELIMO BEN (15 N.m)
<b>x 200</b>	-	-	25	0,086	BELIMO BEN (15 N.m)
<b>x 225</b>	-	-	26	0,103	BELIMO BEN (15 N.m)
<b>x 250</b>	-	4	26,9	0,120	BELIMO BEN (15 N.m)
<b>x 280</b>	-	19	28,1	0,141	BELIMO BEN (15 N.m)
<b>x 300</b>	-	29	28,8	0,154	BELIMO BEN (15 N.m)
<b>x 315</b>	-	36,5	29,4	0,164	BELIMO BEN (15 N.m)
<b>x 355</b>	-	56,5	31	0,191	BELIMO BEN (15 N.m)
<b>x 400</b>	-	79	32,7	0,222	BELIMO BEN (15 N.m)
<b>x 450</b>	-	104	34,6	0,256	BELIMO BEN (15 N.m)
<b>x 500</b>	-	129	36,6	0,290	BELIMO BEN (15 N.m)
<b>x 550</b>	-	154	38,5	0,324	BELIMO BEN (15 N.m)
<b>x 560</b>	-	159	38,9	0,330	BELIMO BEN (15 N.m)
<b>x 600</b>	-	179	40,4	0,358	BELIMO BEN (15 N.m)
<b>x 630</b>	-	194	41,6	0,378	BELIMO BEN (15 N.m)
<b>x 650</b>	-	204	42,3	0,391	BELIMO BEN (15 N.m)
<b>x 700</b>	11	229	44,3	0,425	BELIMO BEN (15 N.m)
<b>x 710</b>	16	234	44,6	0,432	BELIMO BEN (15 N.m)
<b>x 750</b>	36	254	46,2	0,459	BELIMO BEN (15 N.m)
<b>x 800</b>	61	279	49,1	0,493	BELIMO BEE (25 N.m)
<b>x 900</b>	111	329	53	0,561	BELIMO BEE (25 N.m)
<b>x 1000</b>	161	379	56,8	0,629	BELIMO BE (40 N.m)
<b>750 x 180</b>	-	-	25	0,077	BELIMO BEN (15 N.m)
<b>x 200</b>	-	-	25,8	0,092	BELIMO BEN (15 N.m)
<b>x 225</b>	-	-	26,8	0,110	BELIMO BEN (15 N.m)
<b>x 250</b>	-	4	27,8	0,127	BELIMO BEN (15 N.m)
<b>x 280</b>	-	19	29	0,149	BELIMO BEN (15 N.m)
<b>x 300</b>	-	29	29,8	0,163	BELIMO BEN (15 N.m)
<b>x 315</b>	-	36,5	30,4	0,174	BELIMO BEN (15 N.m)
<b>x 355</b>	-	56,5	32	0,203	BELIMO BEN (15 N.m)
<b>x 400</b>	-	79	33,8	0,235	BELIMO BEN (15 N.m)
<b>x 450</b>	-	104	35,8	0,271	BELIMO BEN (15 N.m)
<b>x 500</b>	-	129	37,8	0,307	BELIMO BEN (15 N.m)
<b>x 550</b>	-	154	39,8	0,343	BELIMO BEN (15 N.m)
<b>x 560</b>	-	159	40,2	0,350	BELIMO BEN (15 N.m)
<b>x 600</b>	-	179	41,8	0,379	BELIMO BEN (15 N.m)
<b>x 630</b>	-	194	43	0,400	BELIMO BEN (15 N.m)
<b>x 650</b>	-	204	43,8	0,414	BELIMO BEN (15 N.m)
<b>x 700</b>	11	229	45,8	0,450	BELIMO BEN (15 N.m)
<b>x 710</b>	16	234	46,2	0,458	BELIMO BEN (15 N.m)
<b>x 750</b>	36	254	48,8	0,486	BELIMO BEE (25 N.m)
<b>x 800</b>	61	279	50,8	0,522	BELIMO BEE (25 N.m)
<b>x 900</b>	111	329	54,8	0,594	BELIMO BEE (25 N.m)
<b>x 1000</b>	161	379	58,8	0,666	BELIMO BE (40 N.m)
<b>800 x 180</b>	-	-	26	0,083	BELIMO BEN (15 N.m)
<b>x 200</b>	-	-	26,8	0,098	BELIMO BEN (15 N.m)

Size AxB	a	c	Weight [kg]	Effective area $S_{ef}$ [m <sup>2</sup> ]	Actuating mechanism type
<b>800 x 225</b>	-	-	27,9	0,117	BELIMO BEN (15 N.m)
<b>x 250</b>	-	4	28,9	0,136	BELIMO BEN (15 N.m)
<b>x 280</b>	-	19	30,2	0,159	BELIMO BEN (15 N.m)
<b>x 300</b>	-	29	31	0,175	BELIMO BEN (15 N.m)
<b>x 315</b>	-	36,5	31,6	0,186	BELIMO BEN (15 N.m)
<b>x 355</b>	-	56,5	33,3	0,217	BELIMO BEN (15 N.m)
<b>x 400</b>	-	79	35,2	0,251	BELIMO BEN (15 N.m)
<b>x 450</b>	-	104	37,3	0,290	BELIMO BEN (15 N.m)
<b>x 500</b>	-	129	39,3	0,328	BELIMO BEN (15 N.m)
<b>x 550</b>	-	154	41,4	0,367	BELIMO BEN (15 N.m)
<b>x 560</b>	-	159	41,8	0,374	BELIMO BEN (15 N.m)
<b>x 600</b>	-	179	43,5	0,405	BELIMO BEN (15 N.m)
<b>x 630</b>	-	194	44,8	0,428	BELIMO BEN (15 N.m)
<b>x 650</b>	-	204	45,6	0,443	BELIMO BEN (15 N.m)
<b>x 700</b>	11	229	47,7	0,482	BELIMO BEN (15 N.m)
<b>x 710</b>	16	234	48,1	0,489	BELIMO BEN (15 N.m)
<b>x 750</b>	36	254	50,8	0,520	BELIMO BEE (25 N.m)
<b>x 800</b>	61	279	52,9	0,559	BELIMO BEE (25 N.m)
<b>x 900</b>	111	329	57	0,635	BELIMO BE (40 N.m)
<b>x 1000</b>	161	379	61,2	0,712	BELIMO BE (40 N.m)
<b>900 x 180</b>	-	-	28,0	0,093	BELIMO BEN (15 N.m)
<b>x 200</b>	-	-	28,9	0,111	BELIMO BEN (15 N.m)
<b>x 225</b>	-	-	30	0,132	BELIMO BEN (15 N.m)
<b>x 250</b>	-	4	31,2	0,154	BELIMO BEN (15 N.m)
<b>x 280</b>	-	19	32,5	0,180	BELIMO BEN (15 N.m)
<b>x 300</b>	-	29	33,4	0,197	BELIMO BEN (15 N.m)
<b>x 315</b>	-	36,5	34,1	0,210	BELIMO BEN (15 N.m)
<b>x 355</b>	-	56,5	35,9	0,245	BELIMO BEN (15 N.m)
<b>x 400</b>	-	79	37,9	0,284	BELIMO BEN (15 N.m)
<b>x 450</b>	-	104	40,2	0,328	BELIMO BEN (15 N.m)
<b>x 500</b>	-	129	42,4	0,371	BELIMO BEN (15 N.m)
<b>x 550</b>	-	154	44,7	0,414	BELIMO BEN (15 N.m)
<b>x 560</b>	-	159	45,2	0,423	BELIMO BEN (15 N.m)
<b>x 600</b>	-	179	47	0,458	BELIMO BEN (15 N.m)
<b>x 630</b>	-	194	48,3	0,484	BELIMO BEN (15 N.m)
<b>x 650</b>	-	204	49,2	0,501	BELIMO BEN (15 N.m)
<b>x 700</b>	11	229	52,5	0,545	BELIMO BEE (25 N.m)
<b>x 710</b>	16	234	52,9	0,553	BELIMO BEE (25 N.m)
<b>x 750</b>	36	254	54,7	0,588	BELIMO BEE (25 N.m)
<b>x 800</b>	61	279	57	0,631	BELIMO BEE (25 N.m)
<b>x 900</b>	111	329	61,5	0,718	BELIMO BE (40 N.m)
<b>x 1000</b>	161	379	66	0,805	BELIMO BE (40 N.m)
<b>1000 x 180</b>	-	-	30	0,104	BELIMO BEN (15 N.m)
<b>x 200</b>	-	-	31	0,123	BELIMO BEN (15 N.m)
<b>x 225</b>	-	-	32,2	0,148	BELIMO BEN (15 N.m)
<b>x 250</b>	-	4	33,4	0,172	BELIMO BEN (15 N.m)
<b>x 280</b>	-	19	34,9	0,201	BELIMO BEN (15 N.m)
<b>x 300</b>	-	29	35,8	0,220	BELIMO BEN (15 N.m)
<b>x 315</b>	-	36,5	36,6	0,235	BELIMO BEN (15 N.m)
<b>x 355</b>	-	56,5	38,5	0,273	BELIMO BEN (15 N.m)
<b>x 400</b>	-	79	40,7	0,317	BELIMO BEN (15 N.m)
<b>x 450</b>	-	104	43,1	0,365	BELIMO BEN (15 N.m)
<b>x 500</b>	-	129	45,6	0,414	BELIMO BEN (15 N.m)

Size AxB	a	c	Weight [kg]	Effective area $S_{ef}$ [m <sup>2</sup> ]	Actuating mechanism type
<b>1000 x 550</b>	-	154	48	0,462	BELIMO BEN (15 N.m)
<b>x 560</b>	-	159	48,5	0,472	BELIMO BEN (15 N.m)
<b>x 600</b>	-	179	50,4	0,511	BELIMO BEN (15 N.m)
<b>x 630</b>	-	194	51,9	0,540	BELIMO BEN (15 N.m)
<b>x 650</b>	-	204	53,9	0,559	BELIMO BEE (25 N.m)
<b>x 700</b>	11	229	56,3	0,607	BELIMO BEE (25 N.m)
<b>x 710</b>	16	234	56,8	0,617	BELIMO BEE (25 N.m)
<b>x 750</b>	36	254	58,7	0,656	BELIMO BEE (25 N.m)
<b>x 800</b>	61	279	61,2	0,704	BELIMO BE (40 N.m)
<b>x 900</b>	111	329	66	0,801	BELIMO BE (40 N.m)
<b>x 1000</b>	161	379	70,9	0,898	BELIMO BE (40 N.m)
<b>1100 x 180</b>	-	-	32	0,115	BELIMO BEN (15 N.m)
<b>x 200</b>	-	-	33	0,136	BELIMO BEN (15 N.m)
<b>x 225</b>	-	-	34,3	0,163	BELIMO BEN (15 N.m)
<b>x 250</b>	-	4	35,6	0,190	BELIMO BEN (15 N.m)
<b>x 280</b>	-	19	37,2	0,222	BELIMO BEN (15 N.m)
<b>x 300</b>	-	29	38,2	0,243	BELIMO BEN (15 N.m)
<b>x 315</b>	-	36,5	39	0,259	BELIMO BEN (15 N.m)
<b>x 355</b>	-	56,5	41,1	0,302	BELIMO BEN (15 N.m)
<b>x 400</b>	-	79	43,5	0,350	BELIMO BEN (15 N.m)
<b>x 450</b>	-	104	46,1	0,403	BELIMO BEN (15 N.m)
<b>x 500</b>	-	129	48,7	0,457	BELIMO BEN (15 N.m)
<b>x 550</b>	-	154	51,3	0,510	BELIMO BEN (15 N.m)
<b>x 560</b>	-	159	51,8	0,521	BELIMO BEN (15 N.m)
<b>x 600</b>	-	179	53,9	0,563	BELIMO BEN (15 N.m)
<b>x 630</b>	-	194	56,4	0,595	BELIMO BEE (25 N.m)
<b>x 650</b>	-	204	57,5	0,617	BELIMO BEE (25 N.m)
<b>x 700</b>	11	229	60,1	0,670	BELIMO BEE (25 N.m)
<b>x 710</b>	16	234	60,6	0,681	BELIMO BEE (25 N.m)
<b>x 750</b>	36	254	62,7	0,723	BELIMO BEE (25 N.m)
<b>x 800</b>	61	279	65,3	0,777	BELIMO BE (40 N.m)
<b>x 900</b>	111	329	70,5	0,884	BELIMO BE (40 N.m)
<b>x 1000</b>	161	379	75,7	0,990	BELIMO BE (40 N.m)
<b>1250 x 180</b>	-	-	35	0,131	BELIMO BEN (15 N.m)
<b>x 200</b>	-	-	36,1	0,155	BELIMO BEN (15 N.m)
<b>x 225</b>	-	-	37,6	0,186	BELIMO BEN (15 N.m)
<b>x 250</b>	-	4	39	0,216	BELIMO BEN (15 N.m)
<b>x 280</b>	-	19	40,7	0,253	BELIMO BEN (15 N.m)
<b>x 300</b>	-	29	41,9	0,277	BELIMO BEN (15 N.m)
<b>x 315</b>	-	36,5	42,7	0,295	BELIMO BEN (15 N.m)
<b>x 355</b>	-	56,5	45	0,344	BELIMO BEN (15 N.m)
<b>x 400</b>	-	79	47,6	0,399	BELIMO BEN (15 N.m)
<b>x 450</b>	-	104	50,5	0,460	BELIMO BEN (15 N.m)
<b>x 500</b>	-	129	53,3	0,521	BELIMO BEN (15 N.m)
<b>x 550</b>	-	154	56,2	0,582	BELIMO BEN (15 N.m)
<b>x 560</b>	-	159	56,8	0,594	BELIMO BEN (15 N.m)
<b>x 600</b>	-	179	60,1	0,642	BELIMO BEE (25 N.m)
<b>x 630</b>	-	194	61,8	0,679	BELIMO BEE (25 N.m)
<b>x 650</b>	-	204	62,9	0,703	BELIMO BEE (25 N.m)
<b>x 700</b>	11	229	65,8	0,764	BELIMO BEE (25 N.m)
<b>x 710</b>	16	234	66,4	0,776	BELIMO BEE (25 N.m)
<b>x 750</b>	36	254	68,6	0,825	BELIMO BE (40 N.m)
<b>x 800</b>	61	279	71,5	0,886	BELIMO BE (40 N.m)

Size AxB	a	c	Weight [kg]	Effective area S <sub>ef</sub> [m <sup>2</sup> ]	Actuating mechanism type
<b>1250 x 900</b>	111	329	77,2	1,008	BELIMO BE (40 N.m)
<b>x 1000</b>	161	379	89,8	1,129	SCHISCHEK InMax 50.75 (75 N.m)
<b>1400 x 180</b>	-	-	38	0,147	BELIMO BEN (15 N.m)
<b>x 200</b>	-	-	39,2	0,175	BELIMO BEN (15 N.m)
<b>x 225</b>	-	-	40,8	0,209	BELIMO BEN (15 N.m)
<b>x 250</b>	-	4	42,4	0,243	BELIMO BEN (15 N.m)
<b>x 280</b>	-	19	44,2	0,284	BELIMO BEN (15 N.m)
<b>x 300</b>	-	29	45,5	0,311	BELIMO BEN (15 N.m)
<b>x 315</b>	-	36,5	46,4	0,332	BELIMO BEN (15 N.m)
<b>x 355</b>	-	56,5	48,9	0,386	BELIMO BEN (15 N.m)
<b>x 400</b>	-	79	51,7	0,448	BELIMO BEN (15 N.m)
<b>x 450</b>	-	104	54,9	0,516	BELIMO BEN (15 N.m)
<b>x 500</b>	-	129	58	0,585	BELIMO BEN (15 N.m)
<b>x 550</b>	-	154	62,1	0,653	BELIMO BEE (25 N.m)
<b>x 560</b>	-	159	62,7	0,667	BELIMO BEE (25 N.m)
<b>x 600</b>	-	179	65,2	0,722	BELIMO BEE (25 N.m)
<b>x 630</b>	-	194	67,1	0,763	BELIMO BEE (25 N.m)
<b>x 650</b>	-	204	68,4	0,790	BELIMO BEE (25 N.m)
<b>x 700</b>	11	229	71,5	0,858	BELIMO BE (40 N.m)
<b>x 710</b>	16	234	72,1	0,872	BELIMO BE (40 N.m)
<b>x 750</b>	36	254	74,6	0,927	BELIMO BE (40 N.m)
<b>x 800</b>	61	279	77,7	0,995	BELIMO BE (40 N.m)
<b>x 900</b>	111	329	90,8	1,132	SCHISCHEK InMax 50.75 (75 N.m)
<b>x 1000</b>	161	379	97	1,269	SCHISCHEK InMax 50.75 (75 N.m)
<b>1500 x 180</b>	-	-	40	0,158	BELIMO BEN (15 N.m)
<b>x 200</b>	-	-	41,3	0,187	BELIMO BEN (15 N.m)
<b>x 225</b>	-	-	43	0,224	BELIMO BEN (15 N.m)
<b>x 250</b>	-	4	44,6	0,261	BELIMO BEN (15 N.m)
<b>x 280</b>	-	19	46,6	0,305	BELIMO BEN (15 N.m)
<b>x 300</b>	-	29	47,9	0,334	BELIMO BEN (15 N.m)
<b>x 315</b>	-	36,5	48,9	0,356	BELIMO BEN (15 N.m)
<b>x 355</b>	-	56,5	51,5	0,415	BELIMO BEN (15 N.m)
<b>x 400</b>	-	79	54,5	0,481	BELIMO BEN (15 N.m)
<b>x 450</b>	-	104	57,8	0,554	BELIMO BEN (15 N.m)
<b>x 500</b>	-	129	61,1	0,628	BELIMO BEN (15 N.m)
<b>x 550</b>	-	154	65,4	0,701	BELIMO BEE (25 N.m)
<b>x 560</b>	-	159	66,1	0,716	BELIMO BEE (25 N.m)
<b>x 600</b>	-	179	68,7	0,774	BELIMO BEE (25 N.m)
<b>x 630</b>	-	194	70,7	0,818	BELIMO BEE (25 N.m)
<b>x 650</b>	-	204	72	0,848	BELIMO BE (40 N.m)
<b>x 700</b>	11	229	75,3	0,921	BELIMO BE (40 N.m)
<b>x 710</b>	16	234	75,9	0,936	BELIMO BE (40 N.m)
<b>x 750</b>	36	254	78,6	0,994	BELIMO BE (40 N.m)
<b>x 800</b>	61	279	81,9	1,068	BELIMO BE (40 N.m)
<b>x 900</b>	111	329	95,3	1,215	SCHISCHEK InMax 50.75 (75 N.m)
<b>x 1000</b>	161	379	101,9	1,361	SCHISCHEK InMax 50.75 (75 N.m)
<b>1600 x 180</b>	-	-	42	0,169	BELIMO BEN (15 N.m)
<b>x 200</b>	-	-	43,4	0,200	BELIMO BEN (15 N.m)
<b>x 225</b>	-	-	45,1	0,239	BELIMO BEN (15 N.m)
<b>x 250</b>	-	4	46,8	0,278	BELIMO BEN (15 N.m)
<b>x 280</b>	-	19	48,9	0,325	BELIMO BEN (15 N.m)
<b>x 300</b>	-	29	50,3	0,357	BELIMO BEN (15 N.m)
<b>x 315</b>	-	36,5	51,3	0,380	BELIMO BEN (15 N.m)

Size AxB	a	c	Weight [kg]	Effective area $S_{ef}$ [m <sup>2</sup> ]	Actuating mechanism type
1600 x 355	-	56,5	54,1	0,443	BELIMO BEN (15 N.m)
x 400	-	79	57,2	0,514	BELIMO BEN (15 N.m)
x 450	-	104	60,7	0,592	BELIMO BEN (15 N.m)
x 500	-	129	64,2	0,670	BELIMO BEN (15 N.m)
x 550	-	154	68,7	0,749	BELIMO BEE (25 N.m)
x 560	-	159	69,4	0,764	BELIMO BEE (25 N.m)
x 600	-	179	72,1	0,827	BELIMO BEE (25 N.m)
x 630	-	194	74,2	0,874	BELIMO BEE (25 N.m)
x 650	-	204	75,6	0,905	BELIMO BE (40 N.m)
x 700	11	229	79,1	0,984	BELIMO BE (40 N.m)
x 710	16	234	79,8	1,000	BELIMO BE (40 N.m)
x 750	36	254	82,6	1,062	BELIMO BE (40 N.m)
x 800	61	279	86	1,141	BELIMO BE (40 N.m)
x 900	111	329	99,8	1,297	SCHISCHEK InMax 50.75 (75 N.m)
x 1000	161	379	106,7	1,454	SCHISCHEK InMax 50.75 (75 N.m)

If is used the communication and supply device BKNE 230-24, the weight is higher by 0,68 kg.

3.3. For damper (Fig. 4) the open damper blade overlaps the damper body from dimension B = 250 by the value "c" or "a" and "c". These values are specified in the Tab. 3.2.1.

Values "a" and "c" has to be respected when projecting related smoke exhaust ducts.

Fig. 4 Values "a" and "c"

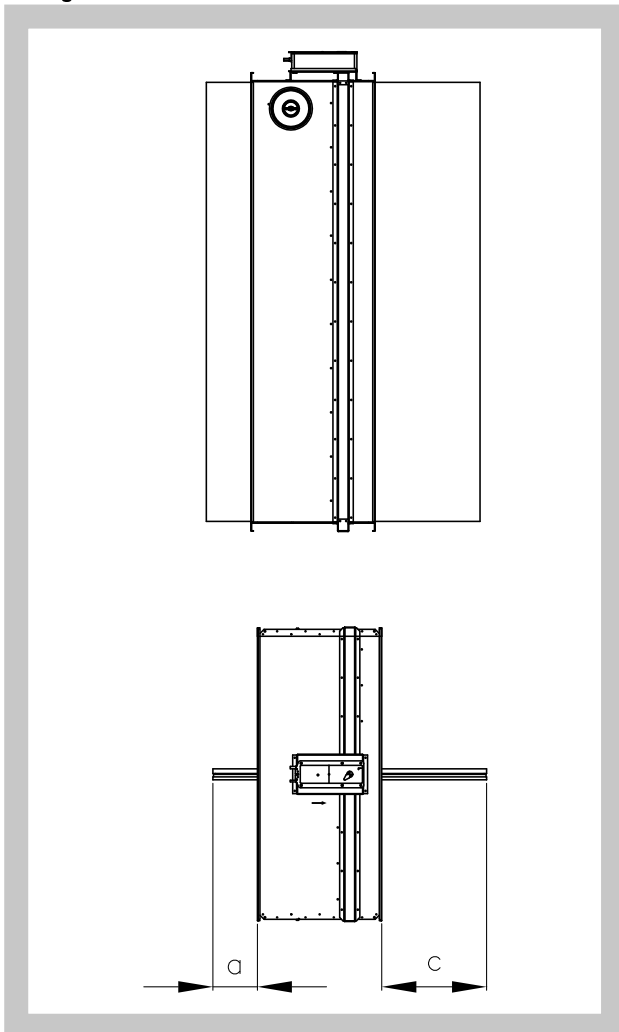

Flanges of dampers are 30 mm wide with oval hole.

Fig. 5 Flanges

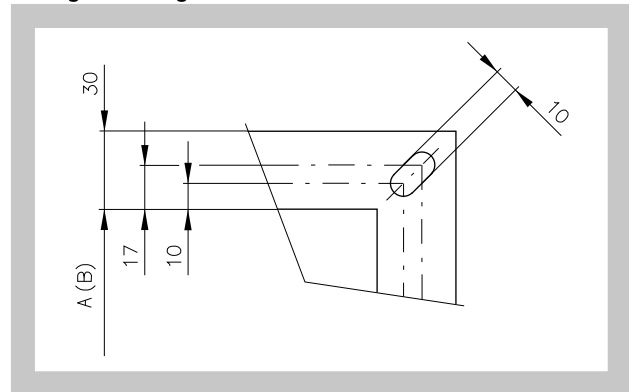

#### 4. Placement and Assembly

- 4.1. Single compartment smoke control damper are designed to remove heat and combustion products (e.g. smoke) from single fire compartment according EN 1366-9. Single compartment smoke control damper are designed for installation with horizontal blade axis. Back-to-back smoke exhaust duct has to be hung or supported so as all load transfer from the back-to-back smoke exhaust duct to the damper is absolutely excluded. To provide needed access space to the control device, all other objects must be situated at least 350 mm from the control parts of the damper.
- 4.2. During installation the damper blade must be in position "CLOSED". The damper body should not be deformed in the course of installation. Once the damper built in, its blade should not grind on the damper body during opening or closing.
- 4.3. Installation examples

Fig. 6 Installation examples

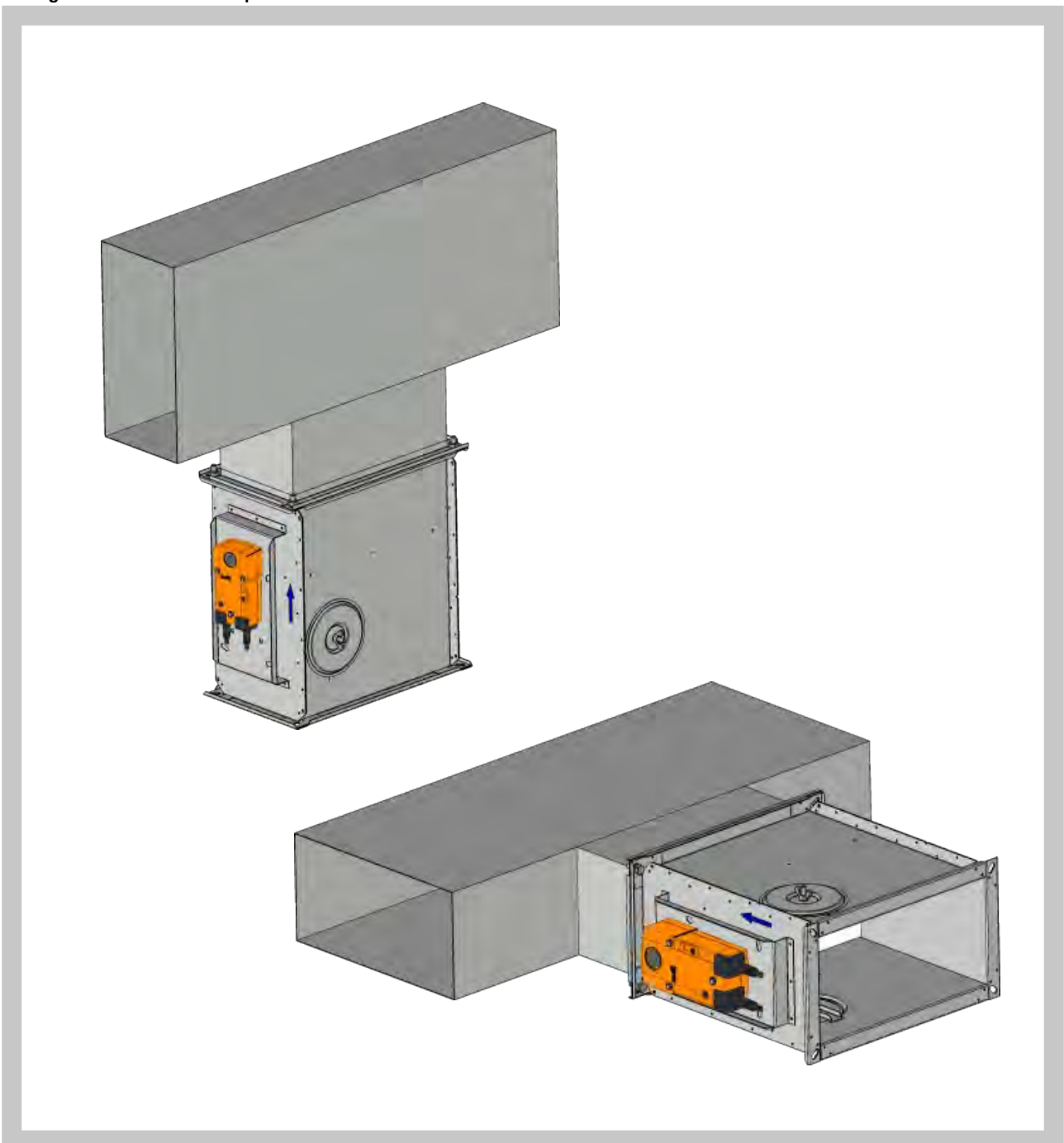

5. Suspension systems

5.1. Mounting to the ceiling wall

Fig. 7 Mounting to the ceiling wall

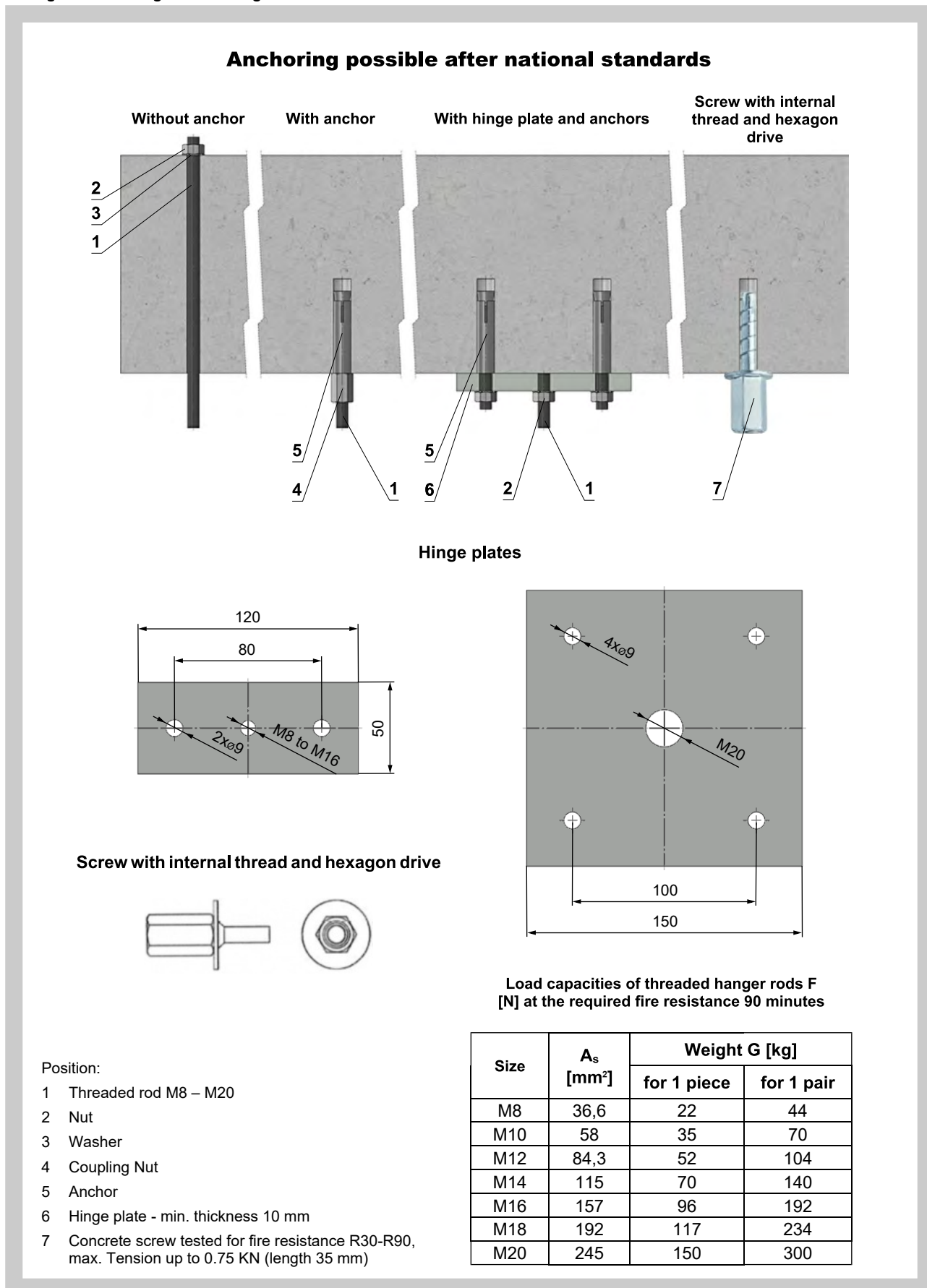

**III. TECHNICAL DATA**

**6. Pressure loss**

**6.1. Pressure loss calculation**

$$\Delta p = \xi \cdot \rho \cdot \frac{w^2}{2}$$

$\Delta p$	[Pa]	pressure loss
$w$	[m.s <sup>-1</sup> ]	air flow speed in nominal damper section
$\rho$	[kg.m <sup>-3</sup> ]	air density
$\xi$	[-]	coefficient of local pressure loss for the nominal damper section (see Tab. 7.1.1.)

**6.2. Determination of pressure loss by using diagram  $\rho = 1,2 \text{ kg.m}^{-3}$**

**Diagram 6.2.1. Pressure losses for air density  $\rho = 1,2 \text{ kg.m}^{-3}$**

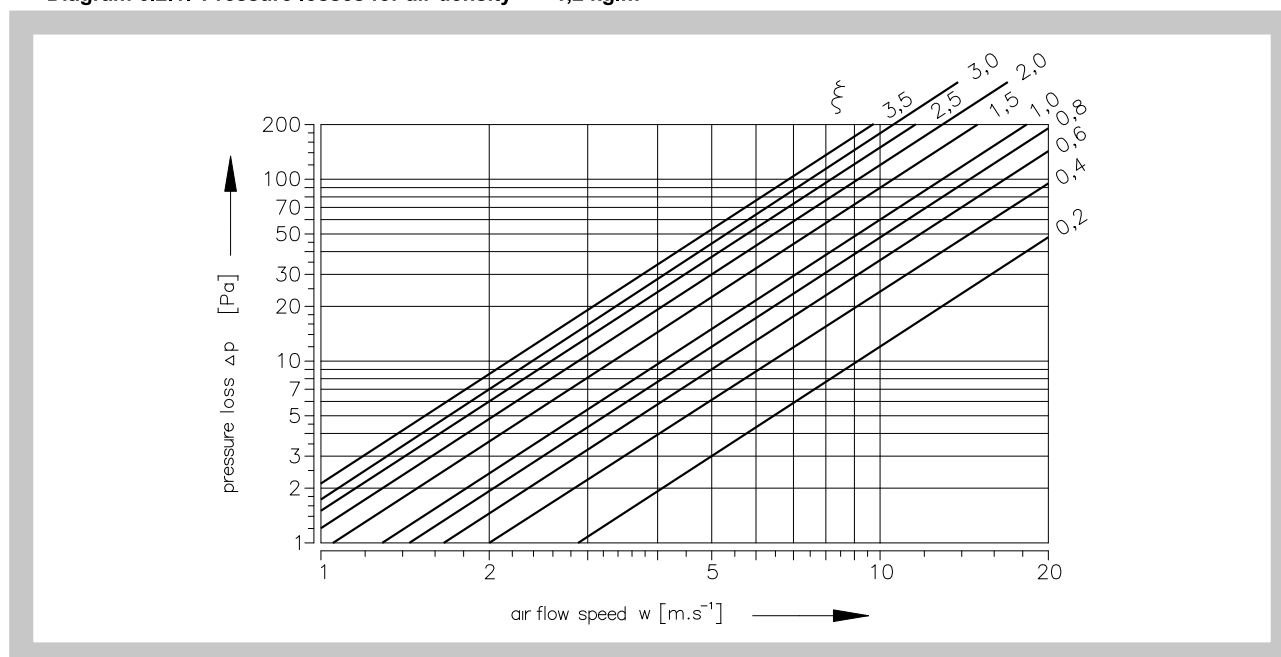

**7. Coefficient of local pressure loss**

**7.1. Coefficient of local pressure loss  $\xi$  (-)**

**Tab. 7.1.1. Coefficient of local pressure loss**

A	B										
	180	200	225	250	280	300	315	355	400	450	500
180	1,849	1,476	1,186	0,983	0,869	0,776	0,703	0,608	0,535	0,478	0,437
200	1,737	1,385	1,152	0,921	0,823	0,736	0,658	0,569	0,500	0,446	0,407
225	1,635	1,296	1,078	0,877	0,778	0,682	0,614	0,543	0,479	0,421	0,386
250	1,553	1,236	1,012	0,819	0,716	0,635	0,583	0,504	0,442	0,394	0,360
280	1,513	1,201	0,981	0,789	0,681	0,618	0,549	0,489	0,426	0,375	0,352
300	1,475	1,166	0,925	0,752	0,669	0,593	0,534	0,475	0,415	0,367	0,331
315	1,415	1,124	0,899	0,728	0,641	0,579	0,518	0,456	0,400	0,356	0,325
355	1,359	1,079	0,856	0,713	0,628	0,545	0,506	0,436	0,383	0,341	0,311
400	1,312	1,041	0,811	0,687	0,601	0,532	0,487	0,420	0,368	0,328	0,299
450	1,271	1,009	0,789	0,665	0,589	0,519	0,471	0,406	0,356	0,317	0,289
500	1,240	0,983	0,786	0,648	0,556	0,499	0,449	0,395	0,346	0,308	0,281
550	1,219	0,971	0,763	0,637	0,543	0,482	0,442	0,389	0,341	0,305	0,278
560	1,211	0,960	0,758	0,632	0,533	0,483	0,437	0,385	0,337	0,300	0,274
600	1,191	0,948	0,753	0,627	0,527	0,473	0,431	0,379	0,331	0,298	0,270
630	1,184	0,938	0,749	0,617	0,521	0,463	0,427	0,376	0,329	0,293	0,267
650	1,179	0,926	0,738	0,613	0,511	0,458	0,425	0,372	0,327	0,291	0,265
700	1,169	0,922	0,736	0,607	0,501	0,453	0,421	0,370	0,324	0,289	0,263
710	1,160	0,919	0,722	0,604	0,502	0,444	0,417	0,368	0,322	0,287	0,261
750	1,151	0,907	0,716	0,599	0,499	0,441	0,411	0,364	0,318	0,285	0,258
800	1,140	0,903	0,711	0,593	0,496	0,438	0,409	0,361	0,316	0,281	0,256
900	1,122	0,888	0,709	0,583	0,484	0,427	0,402	0,355	0,310	0,276	0,252
1000	1,108	0,877	0,706	0,576	0,467	0,418	0,397	0,350	0,306	0,273	0,248
1100	1,095	0,867	0,701	0,569	0,456	0,412	0,392	0,345	0,302	0,269	0,245
1250	1,084	0,857	0,693	0,562	0,455	0,411	0,387	0,342	0,299	0,266	0,242
1400	1,073	0,849	0,688	0,557	0,454	0,410	0,383	0,338	0,296	0,263	0,240
1500	1,067	0,844	0,683	0,554	0,452	0,408	0,381	0,336	0,294	0,262	0,238
1600	1,062	0,840	0,657	0,551	0,451	0,406	0,379	0,334	0,293	0,260	0,237

A	B										
	550	560	600	630	650	700	710	750	800	900	1000
180	0,411	0,400	0,381	0,369	0,352	0,349	0,343	0,331	0,322	0,304	0,291
200	0,385	0,373	0,356	0,344	0,331	0,325	0,320	0,312	0,300	0,284	0,271
225	0,364	0,348	0,336	0,327	0,315	0,311	0,302	0,296	0,281	0,268	0,254
250	0,346	0,330	0,316	0,304	0,294	0,289	0,286	0,278	0,264	0,255	0,239
280	0,327	0,312	0,303	0,291	0,284	0,282	0,278	0,263	0,253	0,248	0,231
300	0,313	0,306	0,291	0,279	0,275	0,272	0,269	0,251	0,246	0,237	0,224
315	0,302	0,297	0,276	0,274	0,263	0,258	0,254	0,241	0,238	0,225	0,215
355	0,288	0,284	0,268	0,262	0,254	0,248	0,243	0,233	0,228	0,215	0,205
400	0,279	0,273	0,263	0,252	0,246	0,241	0,234	0,226	0,219	0,207	0,197
450	0,268	0,264	0,256	0,243	0,238	0,231	0,226	0,221	0,211	0,199	0,190
500	0,265	0,257	0,246	0,236	0,228	0,223	0,219	0,211	0,205	0,194	0,185
550	0,261	0,251	0,244	0,234	0,224	0,221	0,215	0,207	0,203	0,191	0,183
560	0,258	0,250	0,241	0,230	0,221	0,219	0,214	0,203	0,200	0,189	0,180
600	0,257	0,247	0,234	0,228	0,216	0,214	0,211	0,202	0,198	0,186	0,178
630	0,253	0,244	0,231	0,225	0,213	0,210	0,208	0,201	0,195	0,184	0,176
650	0,251	0,241	0,231	0,224	0,212	0,209	0,206	0,200	0,194	0,183	0,175
700	0,250	0,240	0,227	0,223	0,211	0,208	0,205	0,199	0,193	0,181	0,173
710	0,248	0,239	0,224	0,220	0,210	0,206	0,204	0,197	0,191	0,180	0,172
750	0,247	0,237	0,221	0,218	0,209	0,204	0,202	0,195	0,189	0,178	0,169
800	0,246	0,234	0,221	0,215	0,208	0,203	0,200	0,193	0,187	0,176	0,168
900	0,244	0,230	0,221	0,212	0,207	0,201	0,196	0,187	0,184	0,173	0,165
1000	0,236	0,227	0,218	0,209	0,206	0,197	0,193	0,185	0,181	0,171	0,163
1100	0,231	0,224	0,211	0,206	0,201	0,194	0,191	0,182	0,179	0,168	0,161
1250	0,228	0,221	0,208	0,203	0,199	0,193	0,189	0,181	0,176	0,166	0,159
1400	0,225	0,219	0,206	0,201	0,196	0,192	0,187	0,179	0,175	0,165	0,157
1500	0,223	0,218	0,205	0,200	0,194	0,191	0,186	0,178	0,174	0,164	0,156
1600	0,222	0,216	0,203	0,199	0,192	0,190	0,185	0,176	0,173	0,163	0,155

**8. Electrical components, wiring diagrams**

**8.1. Actuating mechanism**

Connection cable has to have minimal 2 minutes fire resistance.

**Tab. 8.1.1. Actuator BELIMO BEN 24(-ST), BEN 230**

Actuator BELIMO - 15 Nm	BEN 24(-ST)	BEN 230
Power voltage	AC/DC 24 V 50/60Hz	AC 230 V 50/60Hz
Power consumption - in operation - in the end position	3 W 0,1 W	4 W 0,4 W
Dimensioning	6 VA (Imax 8,2 A @ 5 ms)	7 VA (Imax 4 A @ 5 ms)
Protection class	III	II
Degree of protection	IP 54	
Adjustment time for 95°	< 30 s	
Ambient temperature Storage temperature	-30°C ... +55°C -40°C ... +80°C	
Connection - drive - auxiliary switch	Cable 1 m, 3 x 0,75 mm <sup>2</sup> Cable 1 m, 6 x 0,75 mm <sup>2</sup> (BEN 24-ST) with plug connectors	Cable 1 m, 3 x 0,75 mm <sup>2</sup> Cable 1 m, 6 x 0,75 mm <sup>2</sup>

**Fig. 8 Actuator BELIMO BEN 24(-ST)**

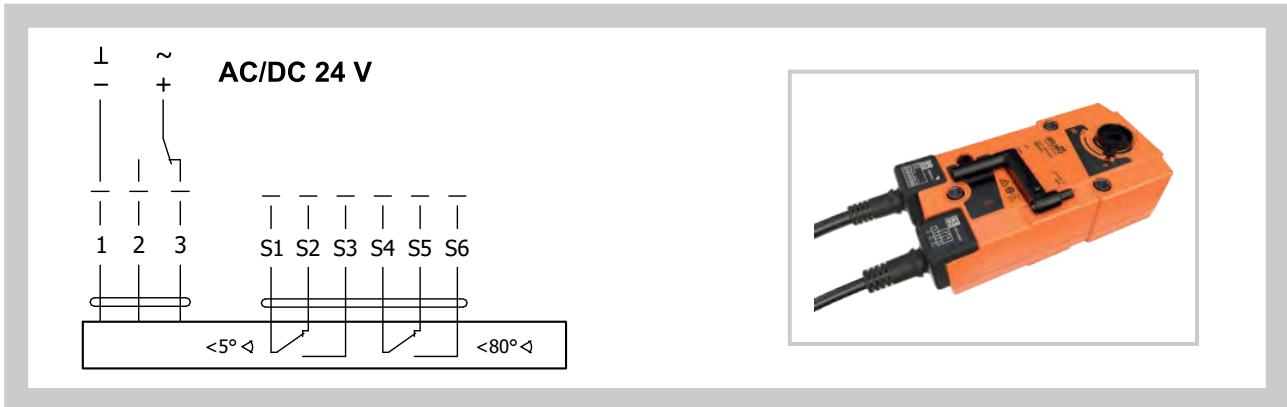

**Fig. 9 Actuator BELIMO BEN 230**

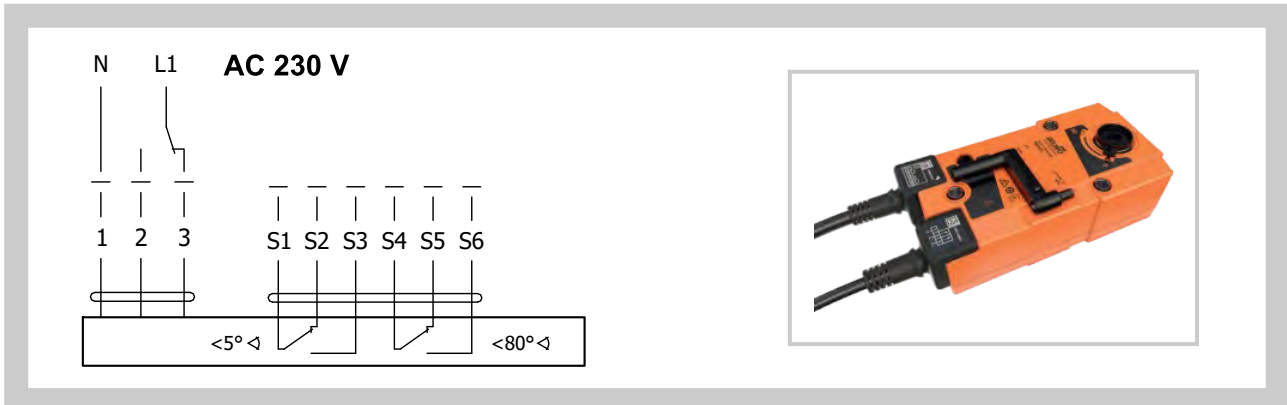

Tab. 8.1.2. Actuator BELIMO BEE 24(-ST), BEE 230

Actuator BELIMO - 25 Nm	BEE 24(-ST)	BEE 230
Power voltage	AC/DC 24 V 50/60Hz	AC 230 V 50/60Hz
Power consumption - in operation - in the end position	2,5 W 0,1 W	3,5 W 0,4 W
Dimensioning	5 VA (I <sub>max</sub> 8,2 A @ 5 ms)	6 VA (I <sub>max</sub> 4 A @ 5 ms)
Protection class	III	II
Degree of protection	IP 54	
Adjustment time for 95°	< 60 s	
Ambient temperature Storage temperature	-30°C ... +55°C -40°C ... +80°C	
Connection - drive - auxiliary switch	Cable 1 m, 3 x 0,75 mm <sup>2</sup> Cable 1 m, 6 x 0,75 mm <sup>2</sup> (BEE 24-ST) with plug connectors	Cable 1 m, 3 x 0,75 mm <sup>2</sup> Cable 1 m, 6 x 0,75 mm <sup>2</sup>

Fig. 10 Actuator BELIMO BEE 24(-ST)

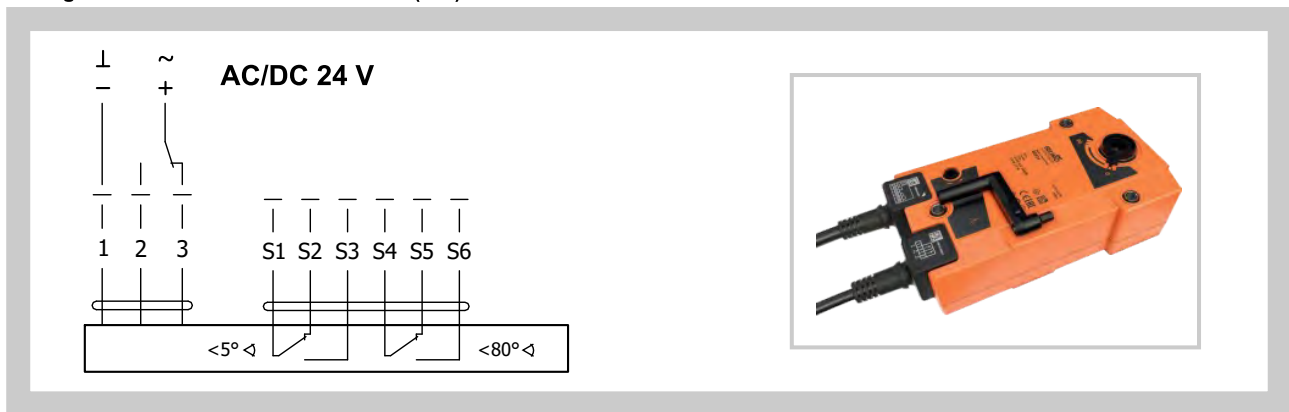
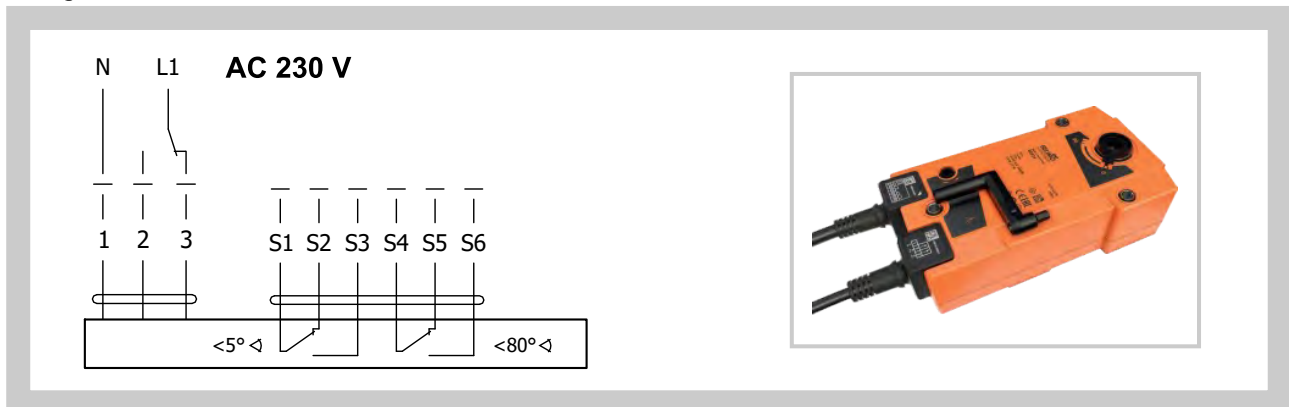

Fig. 11 Actuator BELIMO BEE 230



Tab. 8.1.3. Actuator BELIMO BE 24-12(-ST), BE 230-12

Actuator BELIMO - 40 Nm	BE 24-12(-ST)	BE 230-12
Power voltage	AC/DC 24 V 50/60Hz	AC 230 V 50/60Hz
Power consumption - in operation - in the end position	12 W 0,5 W	8 W 0,5 W
Dimensioning	18 VA (I <sub>max</sub> 8,2 A @ 5 ms)	15 VA (I <sub>max</sub> 7,9 A @ 5 ms)
Protection class	III	II
Degree of protection	IP 54	
Adjustment time for 95°	< 60 s	
Ambient temperature Storage temperature	-30°C ... +50°C -40°C ... +80°C	
Connection - drive - auxiliary switch	Cable 1 m, 3 x 0,75 mm <sup>2</sup> Cable 1 m, 6 x 0,75 mm <sup>2</sup> (BE 24-ST) with plug connectors	

Fig. 12 Actuator BELIMO BE 24-12(-ST)

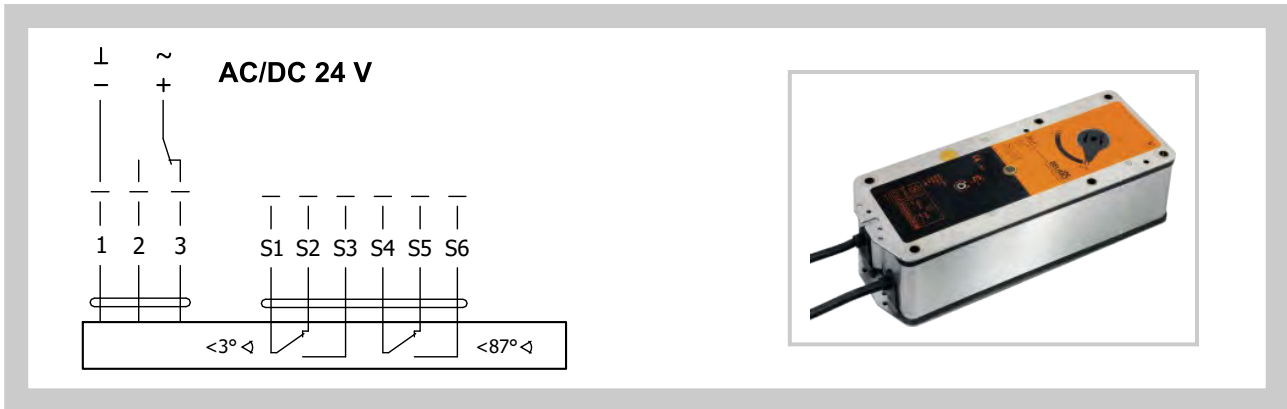
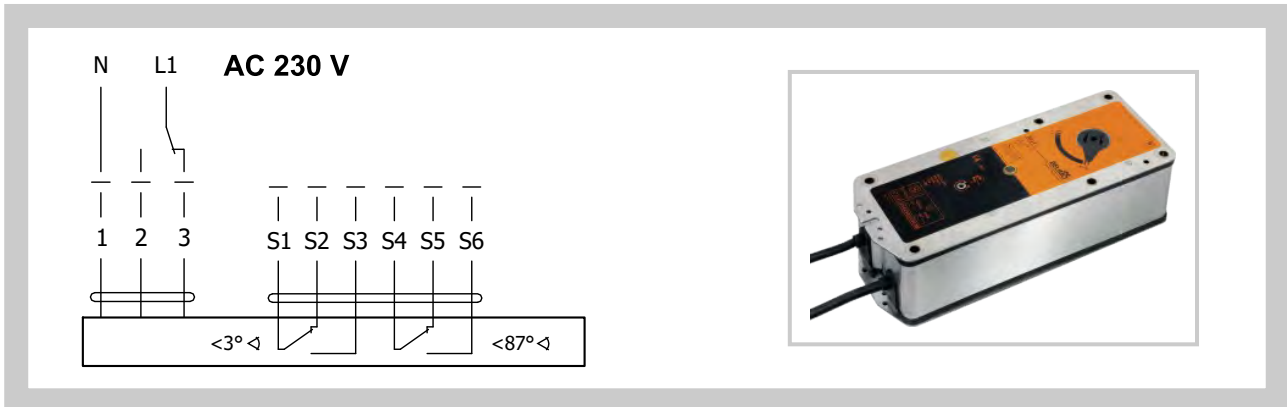

Fig. 13 Actuator BELIMO BE 230-12



Tab. 8.1.4. Actuating mechanism SCHISCHEK InMax 50.75-S

Actuator SCHISCHEK	InMax 50.75-S
Nominal voltage	24-240 VAC/DC 50/60Hz
Power consumption - motoring - heating	10 W 16 W (start at -20°C)
Protection class	I
Degree of protection	IP 66
Running time for 95°	< 60 s
Ambient temperature range	-40°C ... +50°C
Non-operating temperature	-40°C ... +70°C
Connecting	Cable 1 m, 0,5 mm <sup>2</sup>

Fig. 14 Actuating mechanism SCHISCHEK InMax 50.75-S

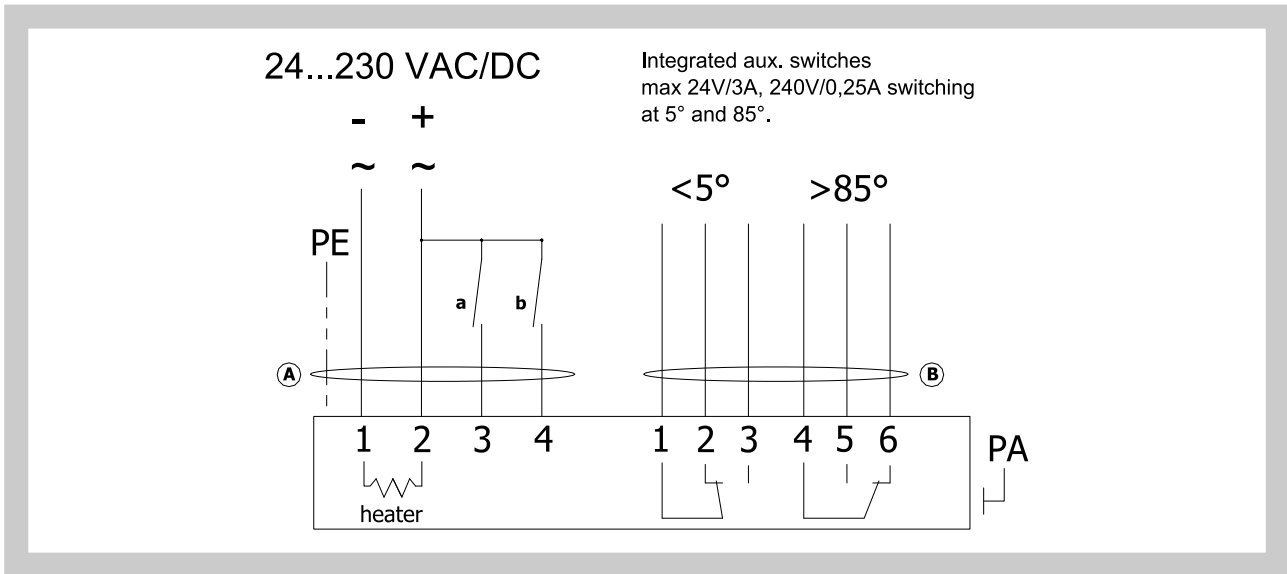

8.2. Communication and supply device

Tab. 8.2.1. Communication and power supply device BKNE 230-24

Communication and power supply device	BKNE 230-24
Power voltage	AC 230V 50/60Hz
Power consumption	10 W (including actuator)
Dimensioning	19 VA (including actuator)
Protection class	II
Ambient operation temperature	-30°C ... +50°C
Storage temperature	-40°C ... +80°C
Connection - network - drive - terminal blocks	cable 1 m without plug 6-pin plug, 3-pin plug screw terminals for 2x1.5 mm <sup>2</sup> conductor

Fig. 15 Communication and power supply device BKNE 230-24

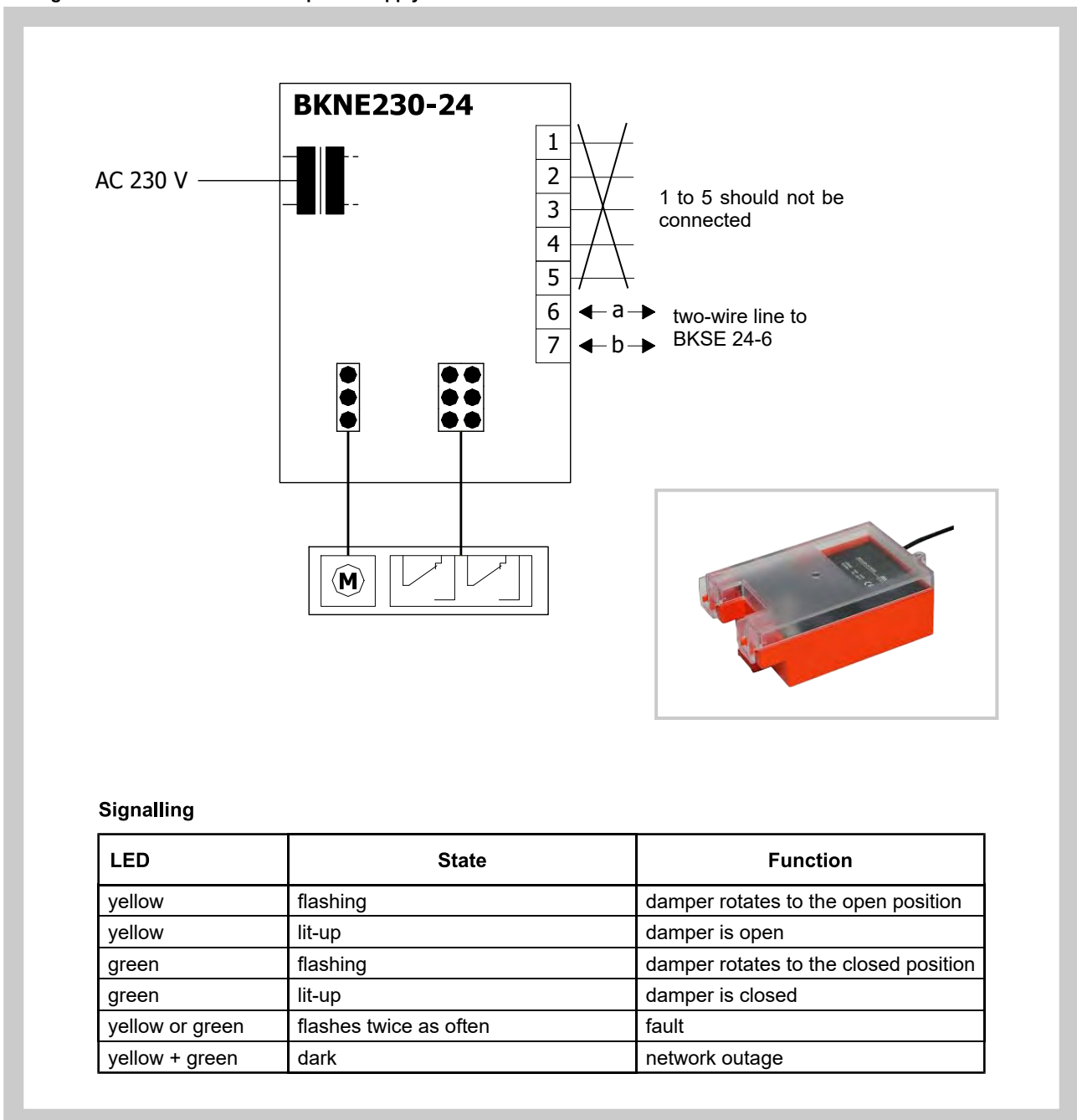

8.3. Communication and control devices

**BKSE 24-6** indicates operating condition and faults of flue dampers. These conditions can be signalled or transmitted to the higher-level control system via the auxiliary built-in contacts. Signals from individual BKNE 230-24 are evaluated separately. All BKNE 230-24 are controlled simultaneously. A maximum of 6 BKNE 230-24 can be connected to the BKSE 24-6.

Damper control is ensured with a simple 2-wire line. The damper's correct function is indicated by two LEDs. The operating status of the entire control system and any errors are indicated by these LEDs and the corresponding error LED.

Mounting and connection of BKSE 24-6 can be done on a 35mm DIN rail. It's connected using two 9-pin terminal blocks (plug connectors).

Tab. 8.3.1. Communication and control devices BKSE 24-6

Communication and control devices	BKSE 24-6
Power voltage	AC 24 V 50/60Hz
Power consumption	3,5 W (operating position)
Dimensioning	5,5 VA 18 VA (I <sub>max</sub> 6.4 A @ 2.5 ms)
Protection class	III (low voltage)
Degree of protection	IP 20
Ambient operation temperature	0 ... +50°C
Connection	screw terminals for 2x1.5 mm <sup>2</sup> conductor

Fig. 16 Communication and control devices BKSE 24-6

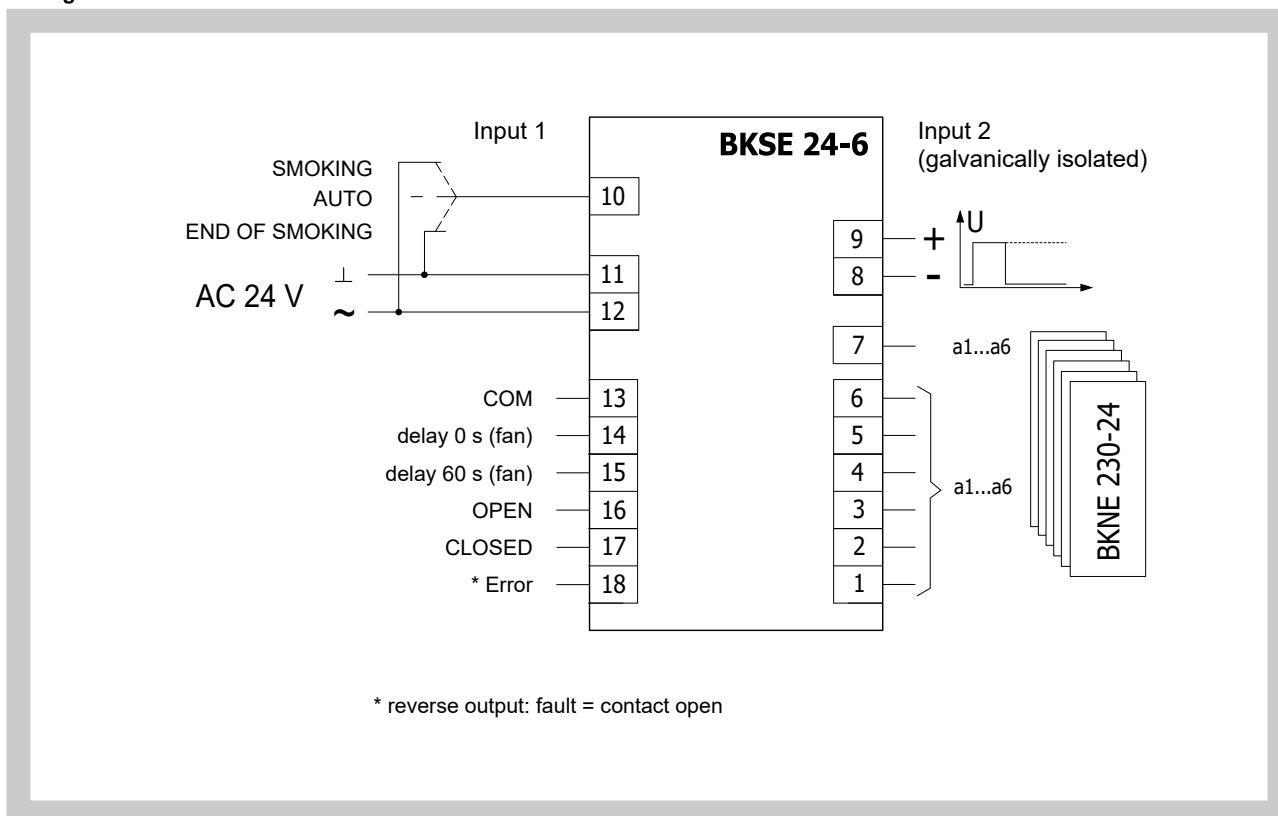

## IV. MATERIAL, FINISHING

### 9. Material

**9.1.** Damper casings are made of galvanized plate without any other surface finish. Damper blades are made of fire resistant asbestos free boards made of mineral fibres. Fasteners are galvanized.

**9.2.** According to the customer's requirements, damper can be made of stainless material.

Specifications for stainless-steel models – classification of stainless steel:

- Class A2 – Food-grade stainless steel (AISI 304 – EN 17240)
- Class A4 – Chemistry-grade stainless steel (AISI 316, 316L – EN 17346, 17349)

The respective stainless steel is the material for all components present or accessing the damper interior; components outside the damper body are typically from galvanised sheet metal (fasteners for mounting the servo drive or mechanics, mechanics components except Item 4), frame components.

The following components, including the fasteners, are made from stainless steel at all times:

- 1) Damper body and all components permanently attached
- 2) Leaf holders, including pins, metal parts of leaf
- 3) Control components inside the damper (leaf angle selector, pin with lever)
- 4) Mechanical components entering the interior of damper body (lower sheet of mechanics, lock holder "1", lock lever "2", lock spring, 8 dia. stopper pin, mechanics pin)
- 5) Inspection hole cover including the clip and fasteners (if they are parts of the cover)
- 6) Bearing for torque transfer from the lever with pin on the angle selector at the leaf (made from AISI 440C)

The leaf of the damper is made from two Promatect-H sheets, thickness 20 mm, connected with galvanised nailed "U" connectors which are sealed with Promat K84 from the outside; Promaseal tape is attached to the leaves with stainless-steel nailed "U" connectors.

Plastic, rubber and silicon components, sealants, foaming bands, glass-ceramic seals, housings, brass bearings of the leaf, servo drives, and end switches are identical for all material variants of the dampers.

Some fasteners and components are available in one class of stainless steel; the type will be used in all stainless-steel variants.

The leaf in the variants for chemical environments (Class A4) is always treated with a coating of chemically resistant Promat SR.

Any other requirements for the design shall be considered atypical and shall be addressed on an individual basis.

## V. INSPECTION, TESTING

### 10. Inspection, testing

**10.1.** The appliance is constructed and preset by the manufacturer, its operation is dependent on proper installation and adjustment.

## VI. TRANSPORTATION AND STORAGE

### 11. Logistic terms

- 11.1. Dampers are transported by box freight vehicles without direct weather impact, there must not occur any shocks and ambient temperature must not exceed +50°C. Dampers must be protected against mechanic damages when transported and manipulated. During transportation, the damper blade must be in the "CLOSED" position.
- 11.2. Dampers are stored indoor in environment without any aggressive vapours, gases or dust. Indoor temperature must be in the range from -30°C to +50°C and maximum relative humidity 95% (avoid condensation on the damper body). Dampers must be protected against mechanic damages when transported and manipulated.

## VII. ASSEMBLY, ATTENDANCE, MAINTENANCE AND REVISIONS

### 12. Assembly

- 12.1. Assembly, maintenance and damper function check can be done only by qualified and trained person, i.e. "AUTHORIZED PERSON" according to the manufacturer documentation. All works done on the smoke control dampers must be done according international and local norms and laws.
- 12.2. All effective safety standards and directives must be observed during damper assembly.
- 12.3. To ensure reliable smoke exhaust damper function it is necessary to avoid blocking the closing mechanism and contact surfaces with collected dust, fibre and sticky materials and solvents.
- 12.4. Manual operation  
Without power supply, the damper can be operated manually and fixed in any required position.

### 13. Entry into service and revisions

- 13.1. Before entering the dampers into operation after assembly and after sequential revisions, checks and functionality tests of all designs including operation of the electrical components must be successfully provided and finished. After entering into operation, these revisions must be done according to requirement set by national regulations.  
In case that dampers are found unable to serve for their function for any cause, it must be clearly marked. The operator is obliged to ensure that the damper is put into condition in which it is ready for function and meanwhile he is obliged to provide the fire protection by another appropriate way. Results of regular checks, imperfections found and all-important facts connected with the damper function must be recorded in the "FIRE BOOK" and immediately reported to the operator.
- 13.2. Before entering the dampers into operation after their assembly and by sequential checks, the following checks must be carried out for all designs.  
Visual inspection of proper damper integration, inside damper area, damper blade, contact surfaces and silicon sealing.  
Inspection hole disassembly: release the covering lid by turning the wing nut and while turning the lid right or left release it from the security belt. Then tilt the lid and remove it from its original position.  
Check of damper blade displacement can be realize after actuating mechanism supply connection or signal connection from higher level control systems. Blade displacement from position "OPEN" to position "CLOSED" and return displacement is checked.

### 14. Spare parts

- 14.1. Spare parts are supplied only on basis of an order.

**VIII. PRODUCT DATA**

**15. Nameplate**

15.1. Nameplate is placed on the damper casing

Fig. 17 Nameplate

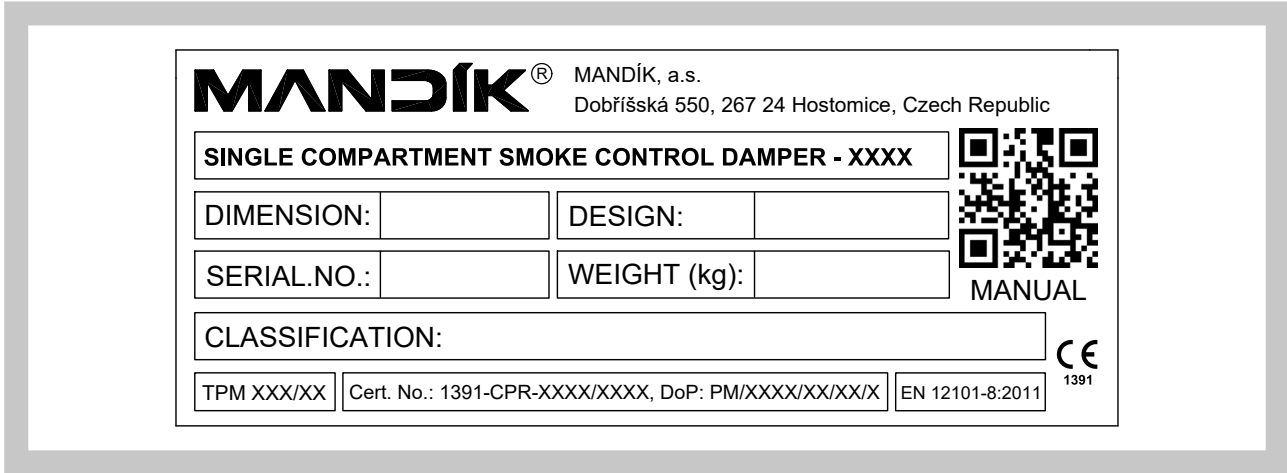

**IX. ORDERING INFORMATION**

**16. Ordering key**

**SEDS 180x355 - .44 TPM 086/12**

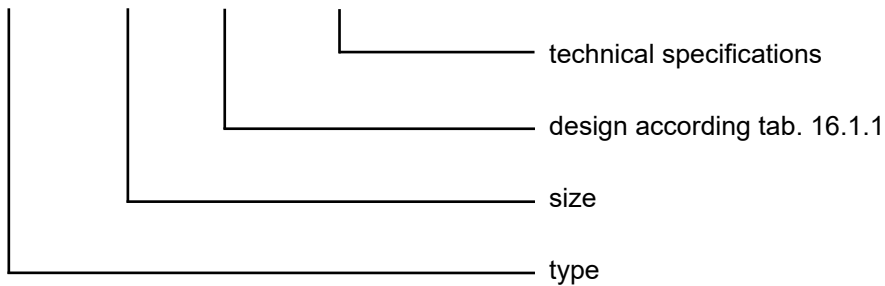

Tab. 16.1.1. Dampers design

Dampers design	Additional digit
with actuating mechanism BEN, BEE, BE, InMax 50.75-S for 230V	.44
with actuating mechanism BEN, BEE, BE, InMax 50.75-S for 24V	.54
with the communication and supply device BKNE 230-24 and actuating mechanism BEN(BEE, BE)-ST for 24V	.66*

\* Design .66 is not available by using actuating mechanism InMax 50.75-S

MANDÍK, a.s.  
Dobříšská 550  
26724 Hostomice  
Czech Republic  
Tel.: +420 311 706 706  
E-Mail: [mandik@mandik.cz](mailto:mandik@mandik.cz)  
[www.mandik.com](http://www.mandik.com)

---

The producer reserves the right for innovations of the product. For actual product information see  
[www.mandik.com](http://www.mandik.com)